

EconoRAY™

Economical, Low-Intensity Infrared Unitary Heating Systems

ER Series Installation, Operation and Service Instructions

INSTALLER

Please take the time to read and understand these instructions prior to any installation

OWNER

Keep this manual in a safe place to provide your serviceman with information if the situation arises.

⚠ WARNING ⚠

Improper installation, adjustment, alteration, service or maintenance can cause property damage, injury or death. Read the installation, operating and maintenance instructions thoroughly before installing or servicing this equipment.



Roberts  Gordon

⚠ WARNING ⚠

FIRE OR EXPLOSION HAZARD

Can cause property damage, severe injury or death.

- 1) Read this manual carefully before installing or servicing this equipment. Improper installation, service or maintenance can cause property damage, injury or death.
- 2) Check clearances given on the outside of each burner to make sure the product is suitable for your application.
- 3) Installer must be a trained, experienced service technician or representative.
- 4) All service must be performed only by a trained service technician or representative.
- 5) After installation is complete, check product operation as provided in these instructions.

©1994 **Roberts-Gordon, Inc.**

All rights reserved. No part of this work covered by the copyrights herein may be reproduced or copied in any form or by any means—graphic, electronic, or mechanical, including photocopying, recording, taping, or information storage and retrieval systems—without written permission of Roberts-Gordon, Inc.

	SECTION	PAGE
WARNINGS <i>Read this section carefully. Improper installation, adjustment, operation or maintenance can cause property damage, injury or death.</i>	1	pg 0
INTRODUCTION <i>Checking Shipment • Installer Responsibility</i>	2	pg 0
INSTALLATION: Planning <i>National Codes • Critical Considerations • Installation Procedure • Clearances to Combustibles</i>	3	pg 0
INSTALLATION: Assembly <i>Parts List • Assembly Overview • Couplings • Suspension • Elbows • Tube Clamp • Dust Cover • Turbulator • Burner • U-Tubes</i>	4	pg 0
INSTALLATION: Venting and Ducting <i>General Requirements • Unvented Operation • Horizontal Venting • Vertical Venting • Common Venting • Outside Air Collar/Supply Duct</i>	5	pg 2
INSTALLATION: Gas Piping <i>Sizing • Installation</i>	6	pg 2
INSTALLATION: Wiring <i>Line Voltage Thermostat Wiring • Low Voltage Thermostat Wiring • Burner Internal Wiring • Burner Ladder Diagram</i>	7	pg 2
OPERATION/MAINTENANCE <i>Operation • Maintenance • Troubleshooting</i>	8	pg 3
APPENDICES <i>Replacement Parts • Specifications • Warranty</i>	9	pg 3

WARNINGS **Section 1**

⚠ WARNING ⚠

FAILURE TO FOLLOW THESE INSTRUCTIONS CAN CAUSE PROPERTY DAMAGE, SEVERE INJURY OR DEATH:

FIRE OR EXPLOSION HAZARD: COMBUSTIBLES

Failure to maintain the specified minimum clearances to combustibles could result in a serious fire hazard. Do not locate flammable or combustible materials within this distance. Do not locate in hazardous atmospheres containing flammable vapors or combustible dust. Installations in public garages or airplane hangars are permitted when in accordance with ANSI Z83.6 and NFPA-409 and 88 Codes.

FIRE OR EXPLOSION HAZARD: VEHICLES

Minimum clearances must be maintained from vehicles parked below the heater. Signs should be posted in storage areas to specify maximum stacking height to maintain required clearances to combustibles.

FIRE OR EXPLOSION HAZARD: GAS CONNECTION

There is an expansion of the radiant pipe with each firing cycle, and this will cause the burner to move with respect to the gas line. This can cause a gas leak resulting in an unsafe condition if the gas connection is not made strictly in accordance with Figure 17 of these instructions.

FIRE OR EXPLOSION HAZARD: IGNITION

This appliance does not have a pilot. It is equipped with an ignition device which automatically lights the burner. Do not try to light the burner by hand.

MECHANICAL HAZARD: SUSPENSION

Use appropriate suspension hardware, beam clamps (rod or perforated strap) and turnbuckles at predetermined locations. The weight and normal movement of the heating system may cause support failure if the following minimum suspension requirements are not met: distance between supports must be 10 ft. or less; chain size must be 2/0 minimum or equivalent. Failure of the supports can cause property damage, severe injury, or death.

IMPORTANT

**FAILURE TO FOLLOW THESE INSTRUCTIONS CAN CAUSE
PROPERTY DAMAGE OR PERSONAL INJURY.**

Do not use in an atmosphere containing halogenated hydrocarbons or other corrosive chemicals. Some compounds in the air can be drawn into the equipment and can cause an accelerated rate of corrosion of some parts of the heat exchanger. The use of such chemical compounds in or near the enclosure should be avoided where a longer life of the burner, tubing and other parts is desirable.

Caution should be used when running the system near combustible materials such as wood, paper, rubber, etc. Consideration should be given to partitions, storage racks, hoists, building construction, etc. Table 1, Section 3 gives minimum acceptable clearances to combustibles. Clearances as shown in Table 1 are not for use in four-sided enclosures.

If the building has a slight negative pressure or contaminants are present in the air, an outside combustion air supply to the heaters is strongly recommended.

CAUTION

**FAILURE TO FOLLOW THESE INSTRUCTIONS CAN CAUSE
DAMAGE TO THE SYSTEM COMPONENTS.**

Do not high pressure test the gas piping with the burners connected. Failure to follow this procedure will exceed the pressure rating of burner gas controls and this will require complete replacement of these parts.

This heater is designed for heating nonresidential indoor spaces. These instructions, the layout drawing, local codes and ordinances, and applicable standards such as apply to gas piping, electrical wiring, venting, etc., must be thoroughly understood before proceeding with the installation.

INTRODUCTION

Section 2

Roberts-Gordon pioneered low-intensity infrared heating systems in 1962 with the introduction of its revolutionary custom-engineered Co-Ray-Vac system. Now Roberts-Gordon offers its 30 years of infrared expertise in a unitary heater. EconoRay models are low-cost, field assembled infrared heaters that are easy to install and require only minimal maintenance. They are designed to provide years of economical operation and trouble-free service.

Checking Shipment

Check the shipment against the Bill of Lading for shortages. Also, check for external damage to cartons. Note any shortages, and/or external damage to cartons on the Bill of Lading in the presence of the delivery trucker. The delivery trucker should acknowledge any shortages or damage by initialing this "noted" Bill of Lading. Immediately report any claims for damaged material, or shortages that were not evident at the time of shipment, to the carrier and your Roberts-Gordon Sales Representative.

Installer Responsibility

All heaters and associated gas piping should be installed in accordance with applicable specifications and this installation made only by firms (or individuals) well qualified in this type of work. Consult local building inspectors, Fire Marshals or your local Roberts-Gordon Representative for guidance.

EconoRay heaters are installed on the basis of information given in a layout drawing, which together with the cited codes and regulations, comprise the basic information needed to complete the installation. The installer must furnish all needed material that is not furnished as standard equipment, and it is his responsibility to see that such materials, as well as the installation methods he uses, result in a job that is workmanlike and in compliance with all applicable codes.

Roberts-Gordon Factory Representatives have had training and experience in the application of this equipment and can be called on for suggestions about installation which can save material and money.

PLANNING

Section

The following codes and instructions should be followed when planning the installation of the EconoRay heater. In addition to these instructions, the warnings in Section 1 must be carefully adhered to since improper installation may lead to property damage, injury, or death.

National Standards and Applicable Codes

Gas Codes The type of gas appearing on the nameplate must be the type of gas used. Installation must comply with local codes and recommendations of the local gas company, and the *National Fuel Gas Code, ANSI Z223.1 - latest revision*, (same as NFPA Bulletin 54).

- Clearance between the heater and its vent and adjacent combustible material (which is part of the building or its contents) shall be maintained to conform with the *Standard for Installation of Gas Appliances and Gas Piping NFPA-54/ANSI-Z223.1 - latest revision, National Fuel Gas Code*.

Aircraft Hangars Installation in aircraft hangars must be in accordance with the *Standard for Aircraft Hangars, ANSI/NFPA-409 - latest revision*.

- Heaters in aircraft storage or service areas shall be installed at a height of 10 feet above the upper surface of wings or engine enclosures of the highest aircraft which may be housed in the hangar. (This should be measured from the bottom of the heater to the wing or engine enclosure, whichever is highest from the floor).
- In other sections of aircraft hangars, such as shops or office, heaters must not be installed less than eight feet above the floor.
- Heaters installed in aircraft hangars shall be located so as not to be subject to damage by aircraft, cranes, movable scaffolding or other objects.

Public Garages Installation in garages must be made in accordance with the *Standard for Parking Structures NFPA-88A - latest revision* or the *Standard for Repair Garages, NFPA 88B - latest revision*.

- Heaters must not be installed less than eight feet above the floor. Minimum clearances to combustibles must be maintained from vehicles parked below the heater.
- When installed over hoists, minimum clearances to combustibles must be maintained from the uppermost point on the hoist.

Electrical The heater must be electrically grounded in accordance with the *National Electrical Code, ANSI/NFPA-70 - latest revision*. Wiring must conform to the most current National Electrical Code, local ordinances, and any special diagrams furnished.

Venting The venting must be installed in accordance with *NFPA-54/ANSI-Z223.1 - latest revision, National Fuel Gas Code*. Partial information with regard to this code is provided in Section 5 of this installation manual with regard to size and configurations for venting arrangements.

Any portion of flue pipe passing through a combustible wall must be dual insulated or have an approved thimble. Refer to *ANSI Z223.1 - latest revision*.

Hazardous Locations Where there is the possibility of exposure to combustible airborne material or vapor, consult the local Fire Marshall, the fire insurance carrier or other authorities for approval of the proposed installation.

Critical Considerations

EconoRay is a suspended heater. Therefore, its stability, flexibility, and safety are very important. Before starting installation, be sure the system can meet the following requirements:

- Maintain specified clearances to combustibles, and safe distance from heat-sensitive material, equipment and work stations.
- Provide a suspension with vertical length of chain or swinging rod which has at least two inches of horizontal travel for each burner in a straight run. Be sure the suspension system is sufficiently flexible to accommodate thermal expansion which occurs as the system heats up (see Figure 5).
- Provide access to burners for servicing, preferably on both sides, above, and behind for burner removal.
- Provide for a minimum of 18 inches of clearance between burners and building walls. (Always observe minimum clearances to combustibles)
- Be sure the heater has a downward pitch of one-half inch per 20 feet away from the burner.
- Provide signs in storage areas to specify maximum stacking height to maintain required clearances to combustibles.
- Plan location of supports (see Figure 2). Locate a support near all elbows.

Installation Procedure

Take maximum advantage of the building upper structure, beams, joists, purtins, etc., from which to suspend the heater. There is no unique sequence for installation of the tubing. On-site observation will usually reveal a logical sequence. Begin the installation at the most critical dimension. This could save time. Watch for swinging doors, overhead cranes, car lifts, etc. Reflectors and tubing can be installed as you move along. Carefully adjust system pitch at each position to level the heater. Pitch down one-half inch in 20 ft. (away from burner).

- Don't**
- Pressure test the gas line using high pressure (greater than 1/2 PSIG) without closing the high-pressure shutoff cocks. Failure to do so will result in damage to the burners.
- Do**
- Familiarize yourself with local and national codes.
 - Develop a planned procedure which will conserve material and labor on the job.
 - Check to see that all material and equipment is on the job before starting installation.
 - Allow for thermal expansion of the hot tube.
 - Install the gas connector only as shown in instructions. (See Figure 17)
 - Have slip joints where required between reflectors to keep them from buckling or coming apart.
 - Provide one square inch of free air opening to each 1,000 BTU/hr of heater input (but not less than 100 square inches) in enclosed spaces. One opening should be within 12 inches of the top and one within 12 inches of the bottom of the enclosure.

CLEARANCES TO COMBUSTIBLES

TABLE 1: Minimum Clearances to Combustibles (Use Figure 1 as a guide)

Reflector Type	Position	ER-40	ER-60	ER-80	ER-100	ER-125	ER-150	ER-175/200
Standard Reflector	A	4"	4"	4"	4"	6"	6"	6"
	B	22"	30"	33"	35"	37"	39"	45"
	C	50"	60"	63"	68"	71"	73"	78"
	D	22"	30"	33"	35"	37"	39"	45"
45° Tilt	A	4"	4"	4"	6"	6"	8"	8"
	B	4"	4"	4"	4"	4"	4"	4"
	C	45"	54"	60"	68"	72"	74"	79"
	D	42"	50"	56"	60"	65"	68"	73"
U-Tube, Standard	A	-	4"	4"	4"	6"	6"	6"
	B	-	30"	33"	35"	41"	45"	48"
	C	-	60"	66"	73"	76"	78"	83"
	D	-	25"	32"	34"	38"	42"	45"
U-Tube, Opposite 45°	A	-	4"	4"	6"	6"	8"	8"
	B	-	50"	56"	60"	65"	68"	73"
	C	-	54"	60"	68"	72"	74"	79"
	D	-	18"	18"	18"	18"	18"	18"
Unvented	Above	12"	12"	18"	18"	18"	18"	18"
	End	18"	18"	24"	24"	24"	30"	30"
Vented	End	18"	18"	18"	18"	18"	18"	18"

⚠ WARNING ⚠

FIRE OR EXPLOSION HAZARD

In all situations clearances to combustibles must be maintained. Failure to observe clearances to combustibles may result in property damage, severe injury, or death.

Minimum clearances must be maintained from vehicles parked below the heater. Signs should be posted in storage areas to specify maximum stacking height to maintain required clearances to combustibles.

Caution should be used when running the system near combustible materials such as wood, paper, rubber, etc.. Consideration should be given to partitions, storage racks, hoists, building construction, etc..

Table 1 gives minimum acceptable clearances to combustibles. Clearances as shown in Table 1 are not for use in four-sided enclosures.

FIGURE 1: Clearances to Combustibles (Refer to Table 1)

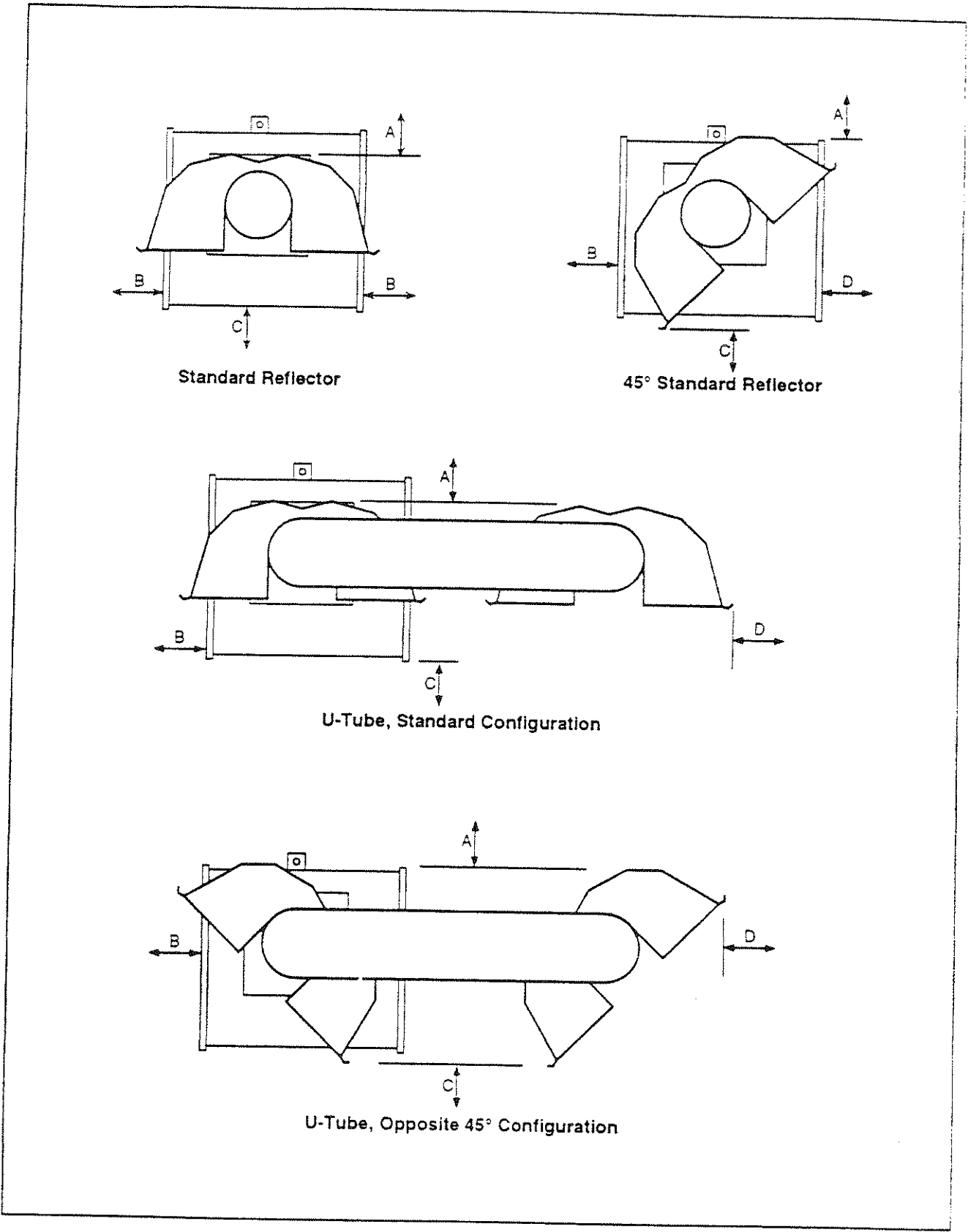

ASSEMBLY

Section 4

The following section provides information about assembling EconoRay heaters. The heaters must be assembled according to the following illustrations and tables in order to ensure safe and proper operation. Please note that Natural and LP units have different assembly requirements.

Table 2 is a guide to which component packages are required to assemble an EconoRay heater, while Table 3 lists the contents of each package. Figure 2 (a,b,c,d,e,f,g,h) shows how to place the components in the system. Figures 3, 4, 5, 6, 7, 8 and 9 show specific assembly details. Refer to Section 5 for venting assembly, Section 6 for gas piping assembly, and Section 7 for field wiring.

TABLE 2: EconoRay Component Package Guide

Model	Burner Fuel	Tubing Length		Required Component Packages		Tubing Packages	
		Minimum	Optional	Reflector/Accessory	Turbulator	Standard	Aluminized
ER-40	Nat	10'	-	ACCPKG10	TURBPKG7	-	-
	Nat	-	20'	ACCPKG20	TURBPKG7	-	ALTUB10
	LP	20'	-	ACCPKG20	-	-	ALTUB20
ER-60	Nat	20'	-	ACCPKG20	TURBPKG7	STDTUB20	ALTUB20
	Nat	-	30'	ACCPKG30	TURBPKG7	STDTUB30	ALTUB30
	LP	30'	-	ACCPKG30	-	STDTUB30	ALTUB30
ER-80	Nat	20'	-	ACCPKG20	TURBPKG7	STDTUB20	ALTUB20
	Nat	-	30'	ACCPKG30	TURBPKG7	STDTUB30	ALTUB30
	LP	30'	-	ACCPKG30	-	STDTUB30	ALTUB30
ER-100	Nat	20'	-	ACCPKG20	TURBPKG12	STDTUB20	ALTUB20
	Nat	-	30'	ACCPKG30	TURBPKG12	STDTUB30	ALTUB30
	LP	30'	-	ACCPKG30	TURBPKG7	STDTUB30	ALTUB30
ER-125	Nat	30'	-	ACCPKG30	TURBPKG10	STDTUB30	ALTUB30
	Nat	-	40'	ACCPKG40	TURBPKG10	STDTUB40	ALTUB40
	Nat	-	50'	ACCPKG20 + ACCPKG30	TURBPKG10	STDTUB50	ALTUB20 + ALTUB30
	LP	40'	-	ACCPKG40	-	STDTUB40	ALTUB40
	LP	-	50'	ACCPKG20 + ACCPKG30	-	STDTUB50	ALTUB20 + ALTUB30
ER-150	Nat	40'	-	ACCPKG40	TURBPKG5	STDTUB40	ALTUB40
	Nat	-	50'	ACCPKG20 + ACCPKG30	TURBPKG5	STDTUB50	ALTUB20 + ALTUB30
	Nat	-	60'	(2) ACCPKG30	TURBPKG5	STDTUB60	(2) ALTUB30
	LP	50	-	ACCPKG20 + ACCPKG30	-	STDTUB50	ALTUB20 + ALTUB30
	LP	-	60	(2) ACCPKG30	-	STDTUB60	(2) ALTUB30
ER-175	Nat/LP	50'	-	ACCPKG20 + ACCPKG30	-	STDTUB50	ALTUB20 + ALTUB30
	Nat/LP	-	60'	(2) ACCPKG30	-	STDTUB60	(2) ALTUB30
	Nat/LP	-	70'	ACCPKG30 + ACCPKG40	-	STDTUB30 + STDTUB40	ALTUB30 + ALTUB40
ER-200	Nat/LP	60'	-	(2) ACCPKG30	-	STDTUB60	(2) ALTUB30
	Nat/LP	-	70'	ACCPKG30 + ACCPKG40	-	STDTUB30 + STDTUB40	ALTUB30 + ALTUB40
	Nat/LP	-	80'	(2) ACCPKG40	-	(2) STDTUB40	(2) ALTUB40

TABLE 3: EconoRay Standard Parts List

Part No.	Contents of ER Burner Shipping Carton	ER-40	-60	-80	-100	-125	-150	-175	-200
035040NG	EconoRay Burner 40,000 Btu/Hr Natural	1	-	-	-	-	-	-	-
035040LP	EconoRay Burner 40,000 Btu/Hr LP	1	-	-	-	-	-	-	-
035060NG	EconoRay Burner 60,000 Btu/Hr Natural	-	1	-	-	-	-	-	-
035060LP	EconoRay Burner 60,000 Btu/Hr LP	-	1	-	-	-	-	-	-
035080NG	EconoRay Burner 80,000 Btu/Hr Natural	-	-	1	-	-	-	-	-
035080LP	EconoRay Burner 80,000 Btu/Hr LP	-	-	1	-	-	-	-	-
035100NG	EconoRay Burner 100,000 Btu/Hr Natural	-	-	-	1	-	-	-	-
035100LP	EconoRay Burner 100,000 Btu/Hr LP	-	-	-	1	-	-	-	-
035125NG	EconoRay Burner 125,000 Btu/Hr Natural	-	-	-	-	1	-	-	-
035125LP	EconoRay Burner 125,000 Btu/Hr LP	-	-	-	-	1	-	-	-
035150NG	EconoRay Burner 150,000 Btu/Hr Natural	-	-	-	-	-	1	-	-
035150LP	EconoRay Burner 150,000 Btu/Hr LP	-	-	-	-	-	1	-	-
035175NG	EconoRay Burner 175,000 Btu/Hr Natural	-	-	-	-	-	-	1	-
035175LP	EconoRay Burner 175,000 Btu/Hr LP	-	-	-	-	-	-	1	-
035200NG	EconoRay Burner 200,000 Btu/Hr Natural	-	-	-	-	-	-	-	1
035200LP	EconoRay Burner 200,000 Btu/Hr LP	-	-	-	-	-	-	-	1
03520100	Combustion Chamber Assy. (Includes Electrode)	1	1	1	1	1	1	1	1
02561300	Gasket (Burner to Transition Tube)	1	1	1	1	1	1	1	1
91907302	S-Hook	1	1	1	1	1	1	1	1
03551100	Choke Plate	1	1	1	-	-	-	-	-
03050800	Inlet Screen	1	1	1	1	1	1	1	1
94310806	Sheet Metal Screws #8 x 3/8"	3	3	3	3	3	3	3	3
95310800	Wide Flat Washer #8	3	3	3	3	3	3	3	3

Part No.	Contents of Ell Reflector/Accessory Packages	ACCPKG10	ACCPKG20	ACCPKG30	ACCPKG40
01312700	Plain Coupling Assembly	1	2	3	4
02750303	Standard 8 ft. Reflector	-	2	4	4
02750307	Standard 5 ft. 6 in. Reflector	2	1	-	2
03090100	Tube and Reflector Hanger	2	3	4	5
03050010	Reflector Support Package	1	2	3	5
01318901	Tube Clamp Package	1	1	1	1
02754600	End Cap	2	2	2	2
91107720	U-Clip Package	1	1	1	1
91907302	S-Hook	2	3	4	5

Part No.	Contents of Turbulator Packages	TURBPKG5	TURBPKG7	TURBPKG10	TURBPKG12
03051503	Turbulator Adapter	1	1	1	1
03051504	Turbulator 2.5ft. Section Piece	2	3	4	5

Part No.	Contents of Standard Tubing Packages	STDTUB20	STDTUB30	STDTUB40	STDTUB50	STDTUB60
91409300	Tube, Hot Rolled Steel, 16 Ga., 10 ft.	1	2	3	4	5
91409403	Tube, Non-Heat Treated Aluminized, 16 Ga., 10 ft.	1	1	1	1	1

Part No.	Contents of (Optional) Aluminized Tubing Packages	ALTUB10	ALTUB20	ALTUB30	ALTUB40
91409408	Tube, Heat Treated Aluminized, 16 Ga., 10 ft.	1	2	3	4

Optional EconoRay Installation Package (P/N 03570100) includes: Flue Pipe Adapter (P/N 90502700), Flexible Gas Connector Assembly (P/N 91412200), Outside Air Collar (P/N 91911700), (3) Sheet Metal Screws #8 x 3/8" (P/N 94310806), (3) Wide Flat Washers #8 (P/N 95310800), Dust Cover (P/N 03551700).

FIGURE 2: EconoRay Assembly Overview Key

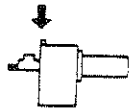

Burner Housing
Suspend from tab on rear.



Suspension Point
Use S-Hooks provided. See Figure 5 for suspension details.



Heat Exchanger Tubes
Supplied in 10 ft. lengths. The first tube immediately after the burner must be aluminized as indicated.



Tube and Reflector Hanger with Clamp Package
Install immediately after first coupling.

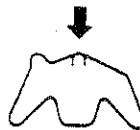

Tube and Reflector Hanger
Suspend system from these hangers. Minimum one (1) required per tube.

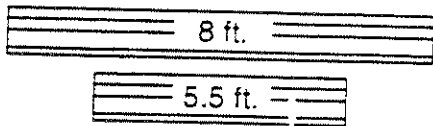

Reflectors
Alternate overlap as shown on overview. Length of reflector and amount of overlap is indicated.



Reflector End Cap
Punch out center section to accommodate tube. Attach with U-Clips provided.

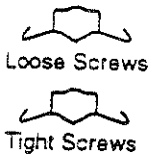

Reflector Support Package
One support is required at every reflector overlap. The support closest to the burner and every other support after should have the screws loosened approx. 1/16" to allow for reflector slippage.



Tube Coupling Assembly
Coupling should be oriented with slide bar on top, and all couplings should "point" in the same direction.



Turbulator Section/Adapter
Turbulators are supplied in sections and must be assembled before installation (see Figure 7 for details).



Vent Adapter
Used to attach the heat exchanger tubing to vent pipe.

FIGURE 2a: EconoRay 10 ft. Heater Assembly Overview

10 ft. heat exchanger length. 11 ft.-8 in. total heater length. 2 suspension points as indicated.

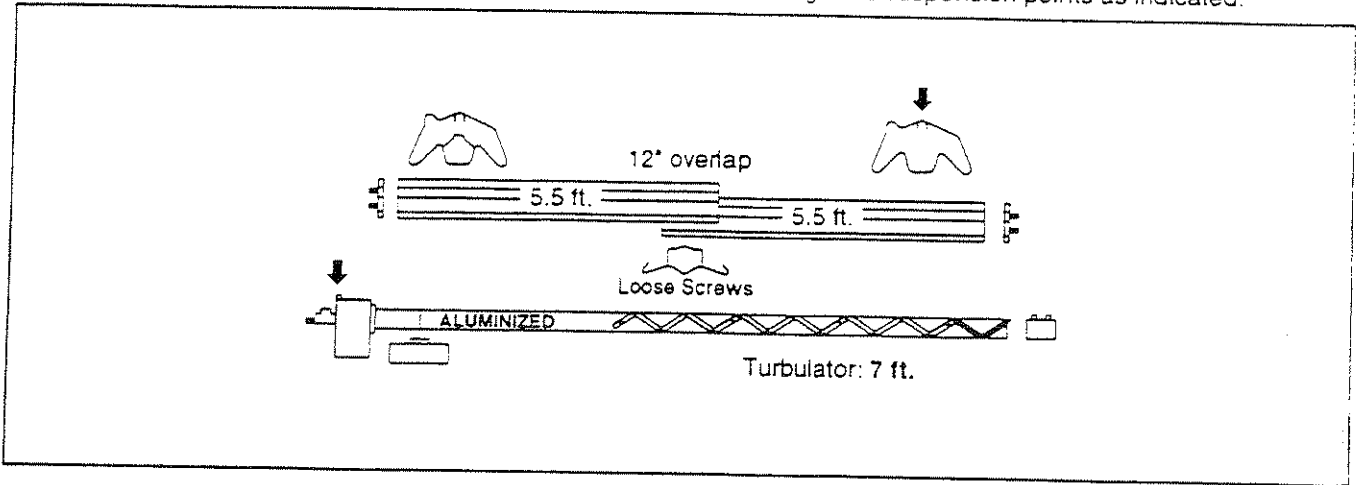

FIGURE 2b: EconoRay 20 ft. Heater Assembly Overview

20 ft. heat exchanger length. 21 ft.-8 in. total heater length. 3 suspension points as indicated.

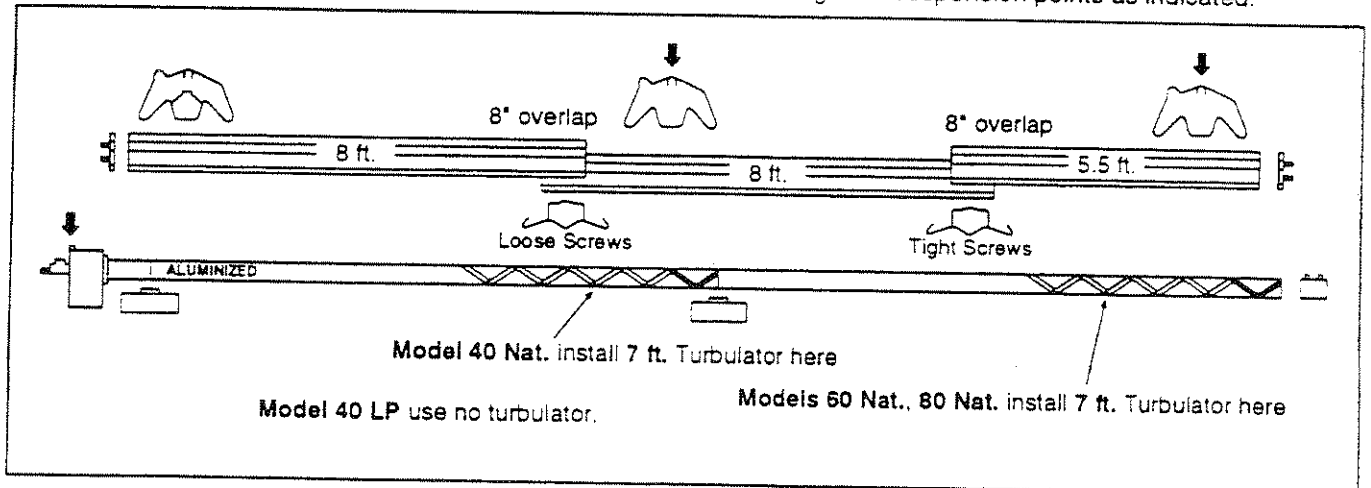
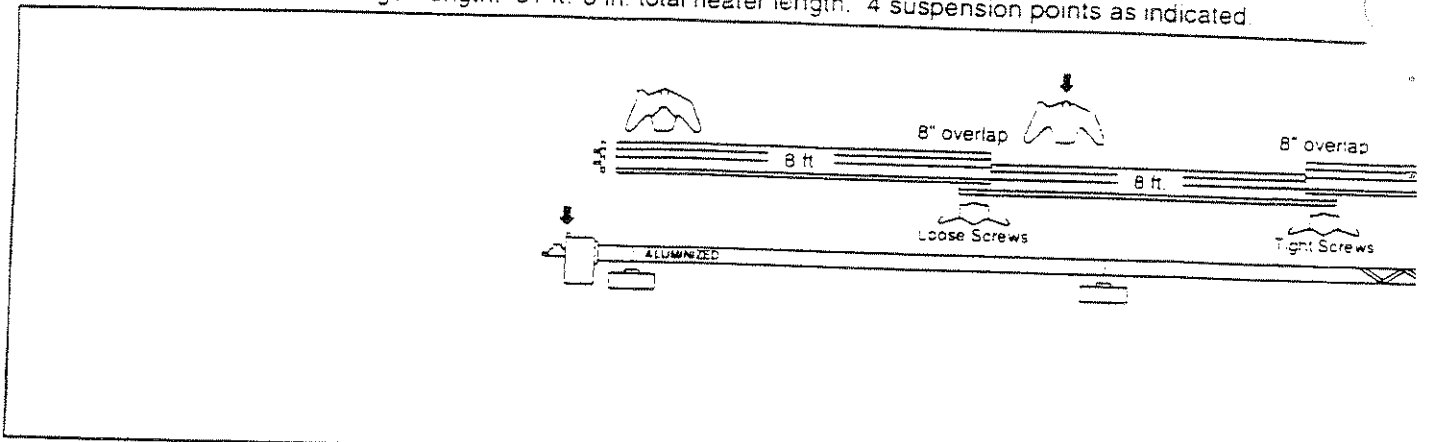

FIGURE 2c: EconoRay 30 ft. Heater Assembly Overview

30 ft. heat exchanger length. 31 ft.-8 in. total heater length. 4 suspension points as indicated.



continued on next page

FIGURE 2d: EconoRay 40 ft. Heater Assembly Overview

40 ft. heat exchanger length. 41 ft.-8 in. total heater length. 5 suspension points as indicated.

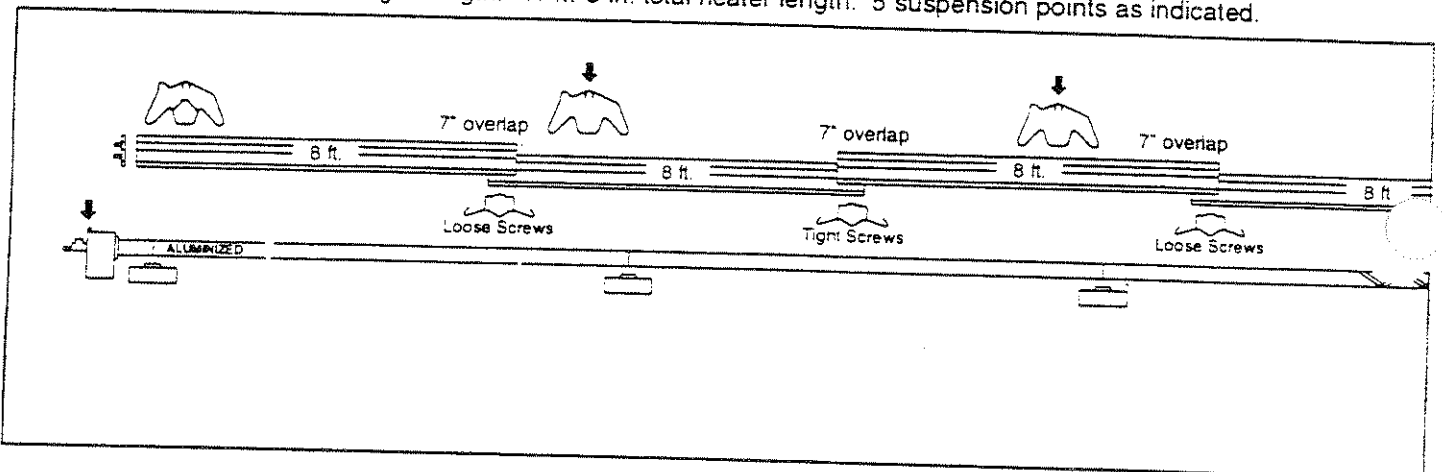

continued on next page

FIGURE 2e: EconoRay 50 ft. Heater Assembly Overview

50 ft. heat exchanger length. 51 ft.-8 in. total heater length. 6 suspension points as indicated.

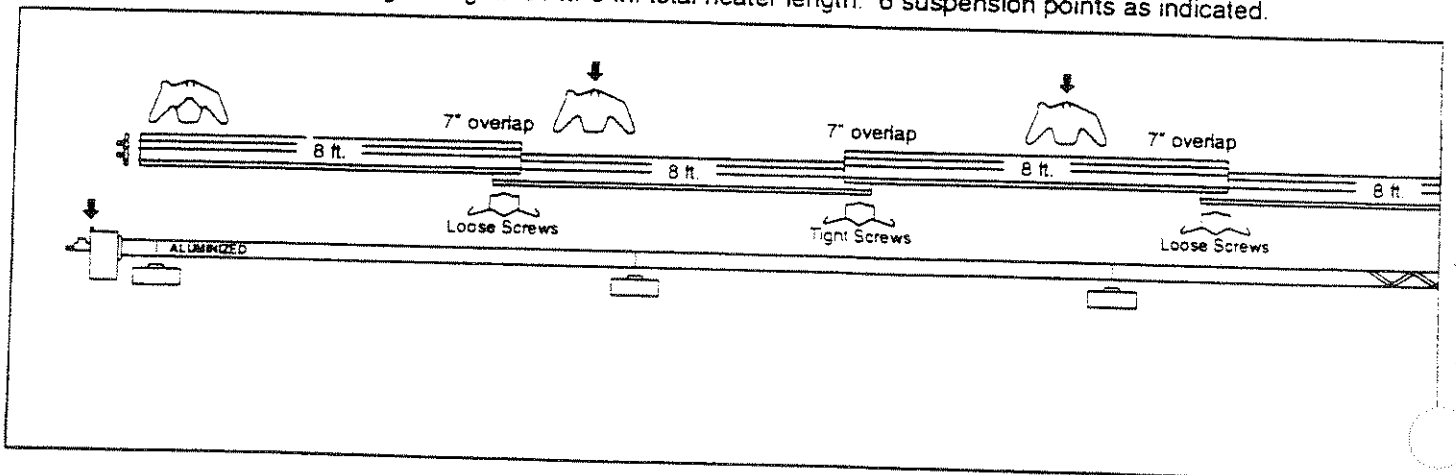

continued on next page

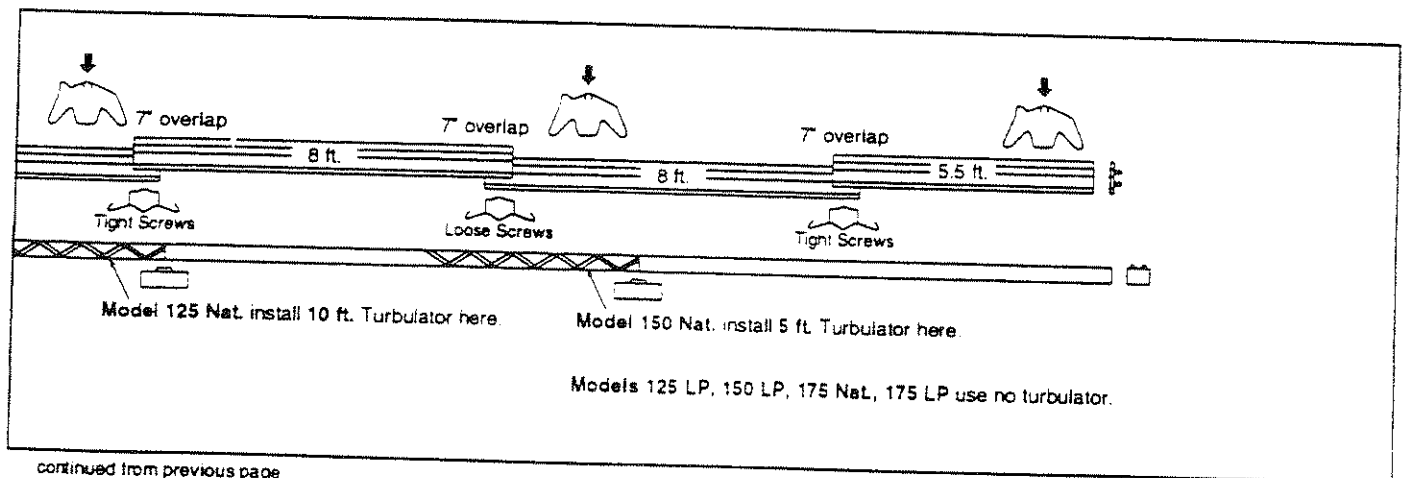
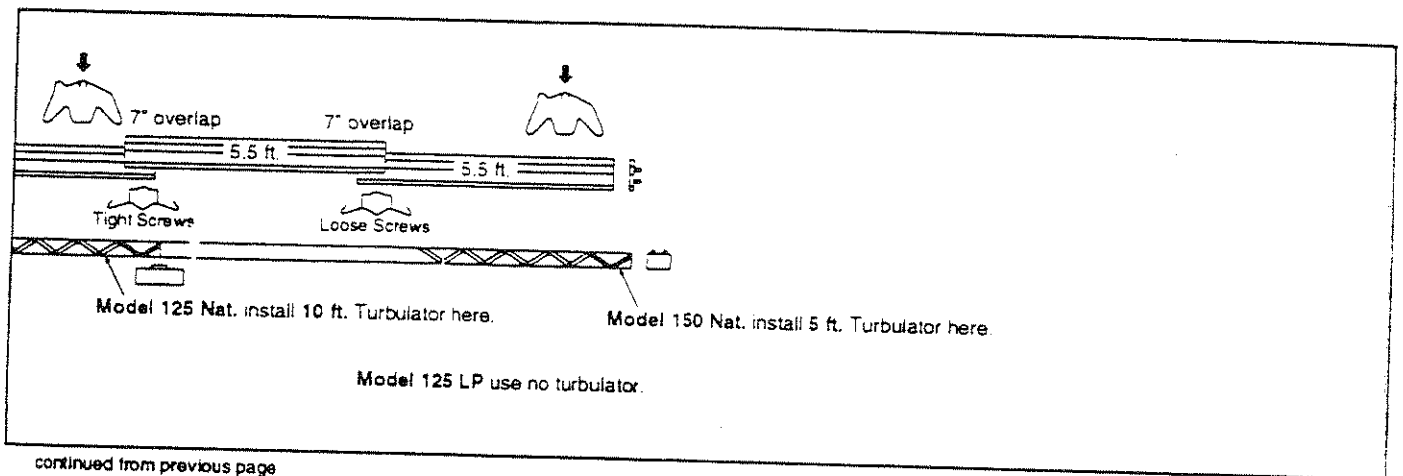
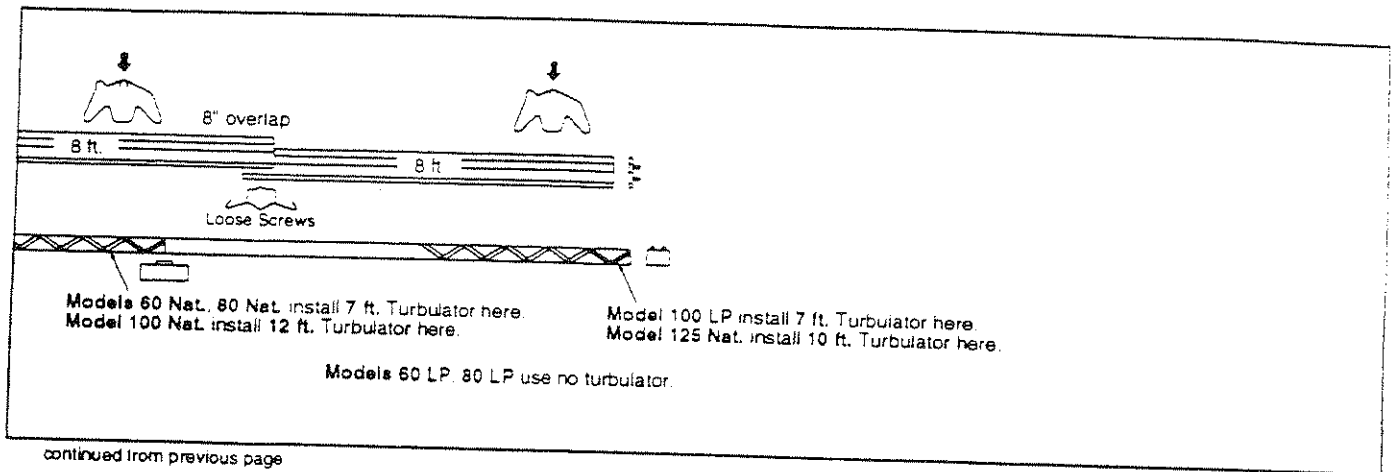
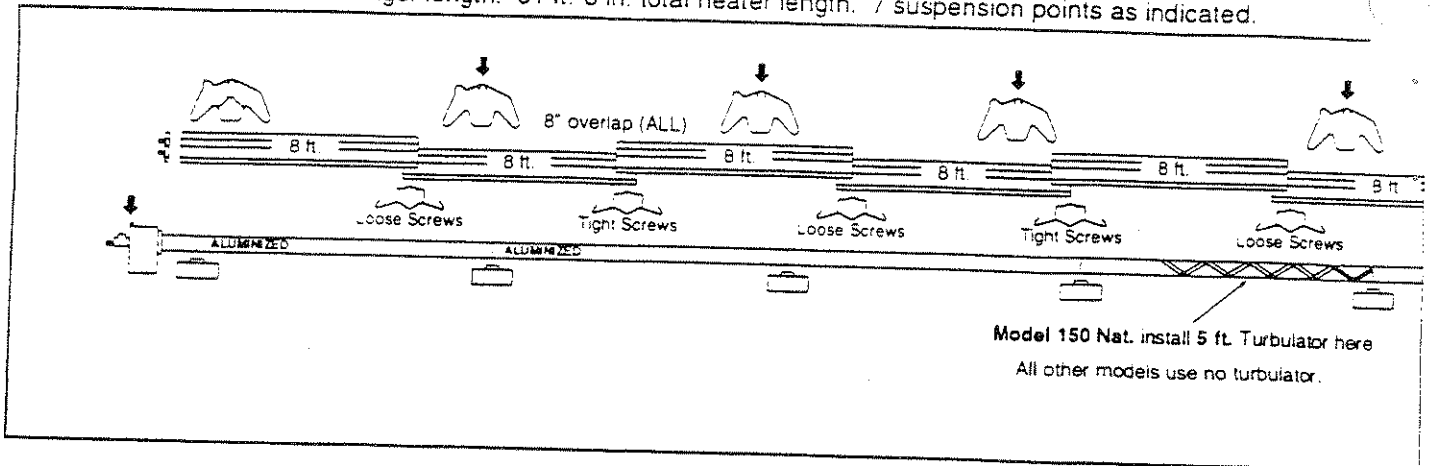

FIGURE 2c: EconoRay 60 ft. Heater Assembly Overview

60 ft. heat exchanger length. 61 ft.-8 in. total heater length. 7 suspension points as indicated.



continued on next page

FIGURE 2d: EconoRay 70 ft. Heater Assembly Overview

70 ft. heat exchanger length. 71 ft.-8 in. total heater length. 8 suspension points as indicated.

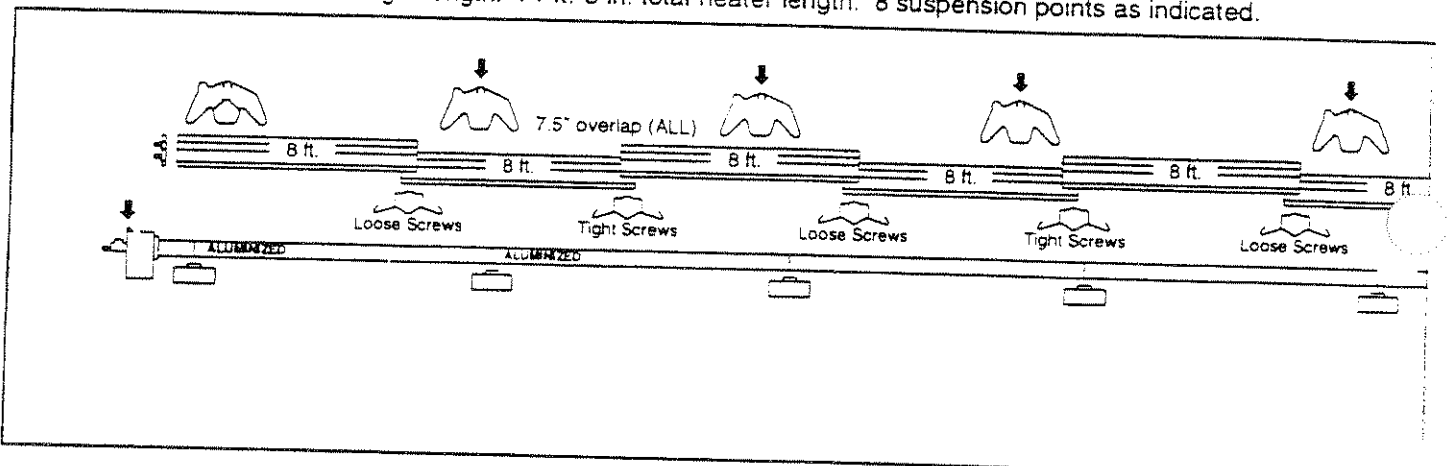

continued on next page

FIGURE 2e: EconoRay 80 ft. Heater Assembly Overview

80 ft. heat exchanger length. 81 ft.-8 in. total heater length. 9 suspension points as indicated.

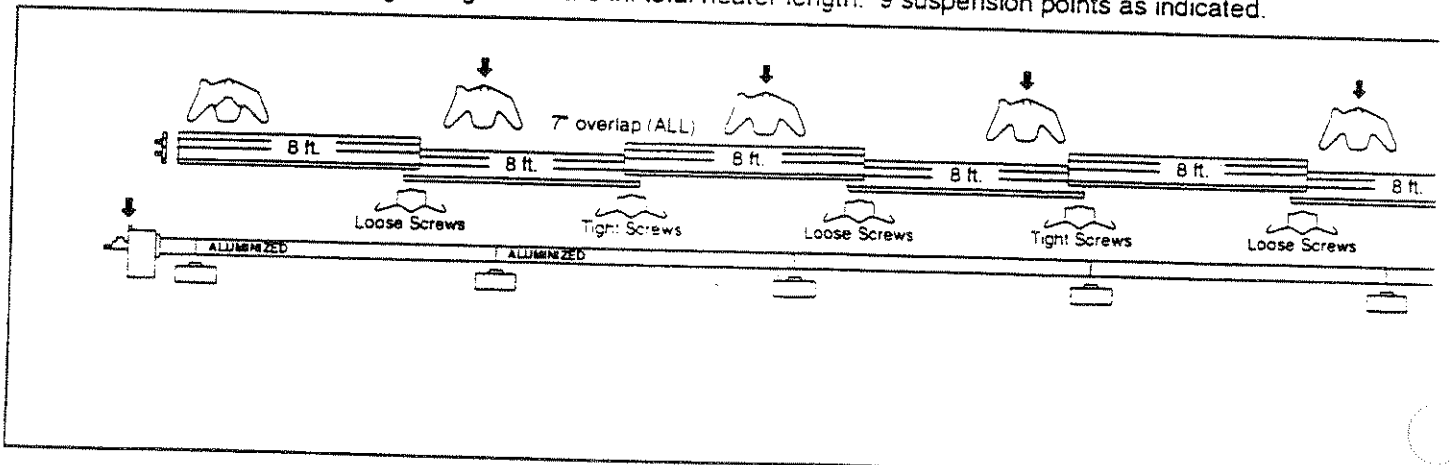

continued on next page

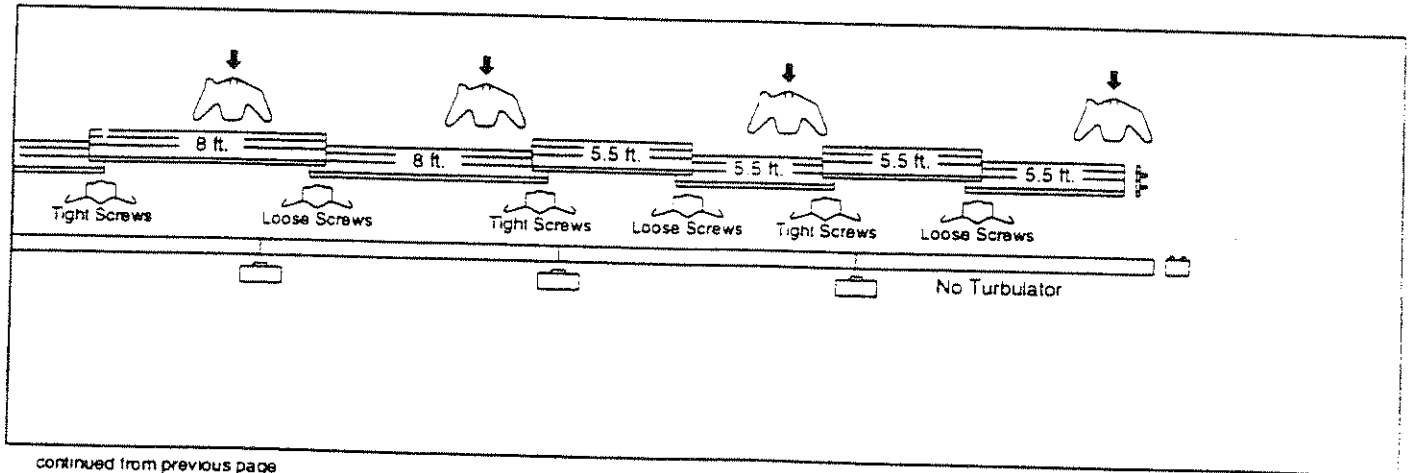
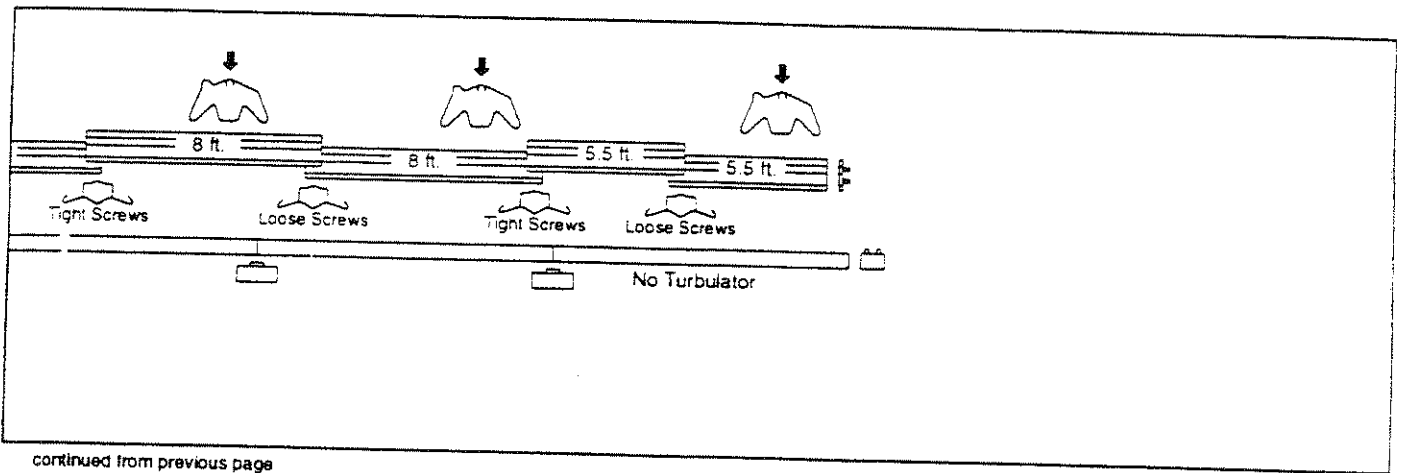
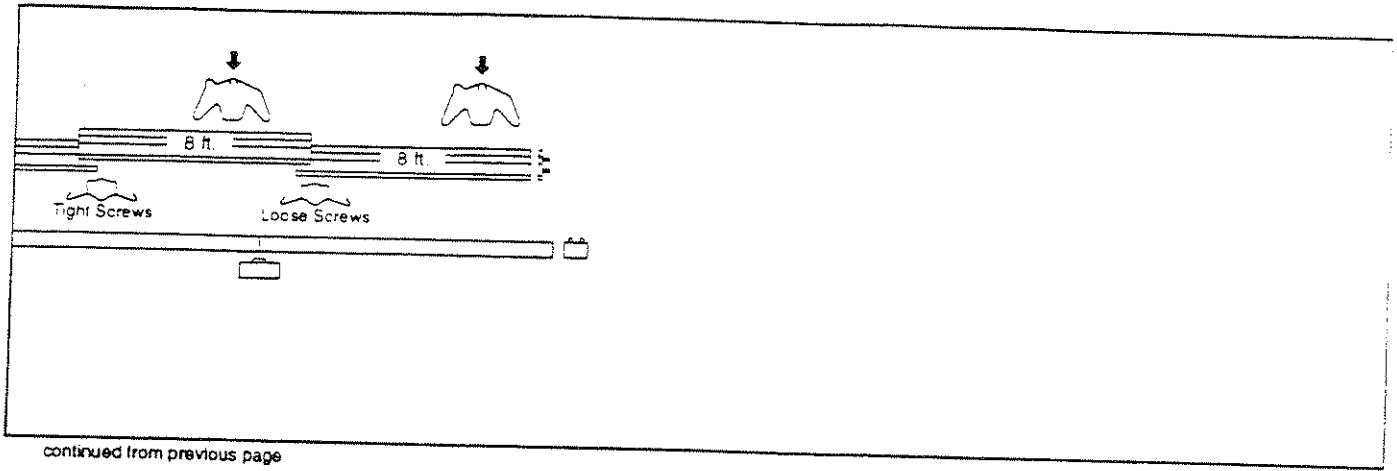

ASSEMBLY (continued)**Section 4**

Assemble the heater components as shown in Figure 2 (a,b,c,d,e,f,g,h). Optional reflector configurations are shown in Figure 1. Install appropriate suspension hardware, beam clamps, chain or rod at predetermined locations. Adjustment of chain length will provide uniform pitch.

Couplings Tube and tube fittings are connected by wrap-around couplings which clamp by means of a tapered, hammer-driven lock member. The starting ends of the coupling and lock member are identified by 1/4" holes which are put together when starting assembly. Be sure the tube ends are in line and tube ends butt against stop pin(s) inside coupling. The slide bar is to be hammer-driven to a point of securing the coupling snugly to the tubes. Over driving will result in distortion of the coupling or slide bar lip to a point decreasing the holding capability of the coupling. Coupling should be tight when the slide bar is $\pm 2"$ from the end of the coupling. See Figure 3.

FIGURE 3: Coupling Assembly

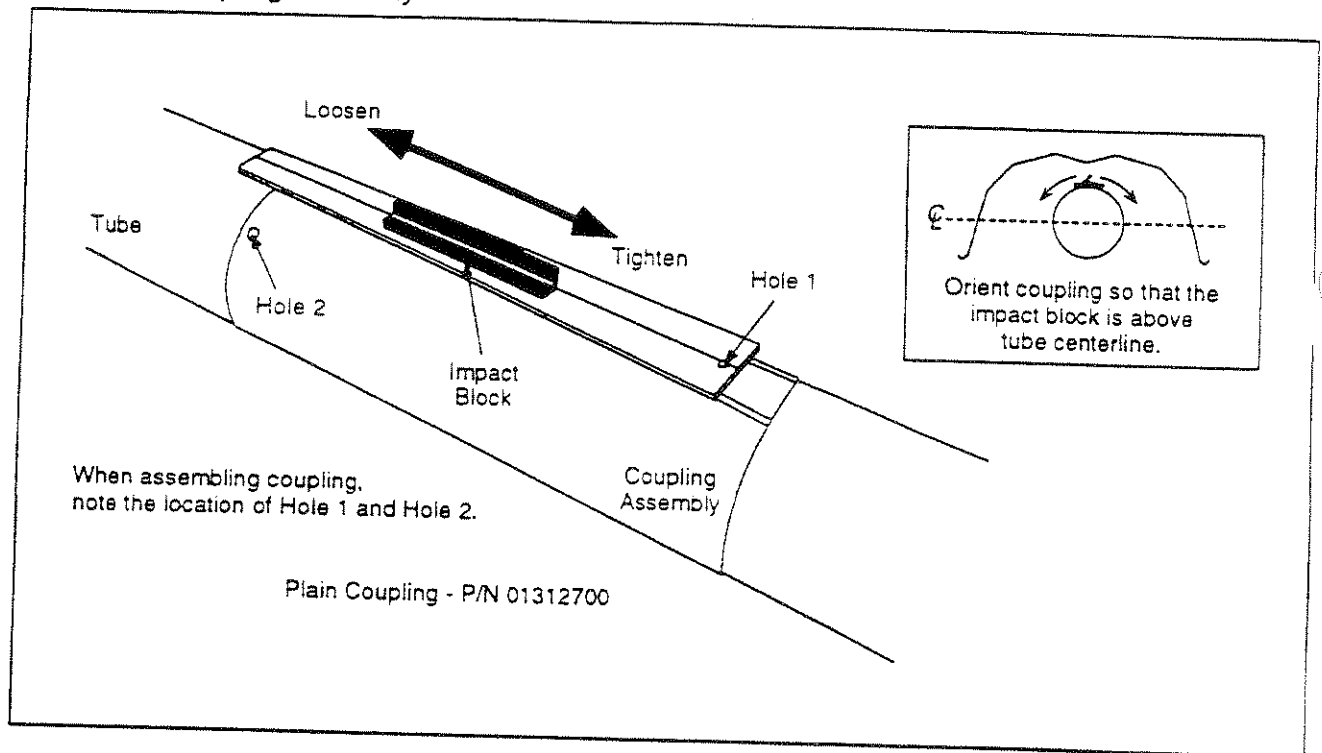

Elbow Package (P/N 02718702) Elbow Package includes: (1) elbow, (1) coupling, (1) end cap, and (1) reflector joint piece. Install elbow into radiant tube sequence where plans indicate a 90° bend. Install reflector joint piece using the following procedure (see Figure 4):

1. Flatten reflector edge where joint piece matches. Put a mark on the reflector, directly over the tube center. Center the accessory joint piece on the mark and scribe its contour on the reflector. Scribe the location of the mounting holes.
2. Cut away the reflector to clear the tube, leaving about one inch of material inside the scribed contour to attach the accessory joint. With an awl or other pointed tool, punch $\frac{3}{16}$ " diameter holes in reflector.
3. Use six No. 10 sheet metal screws to attach the joint piece.

FIGURE 4: Installation of Elbow and Reflector Joint Piece (optional equipment)

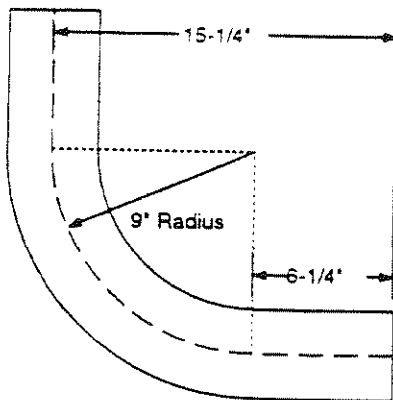
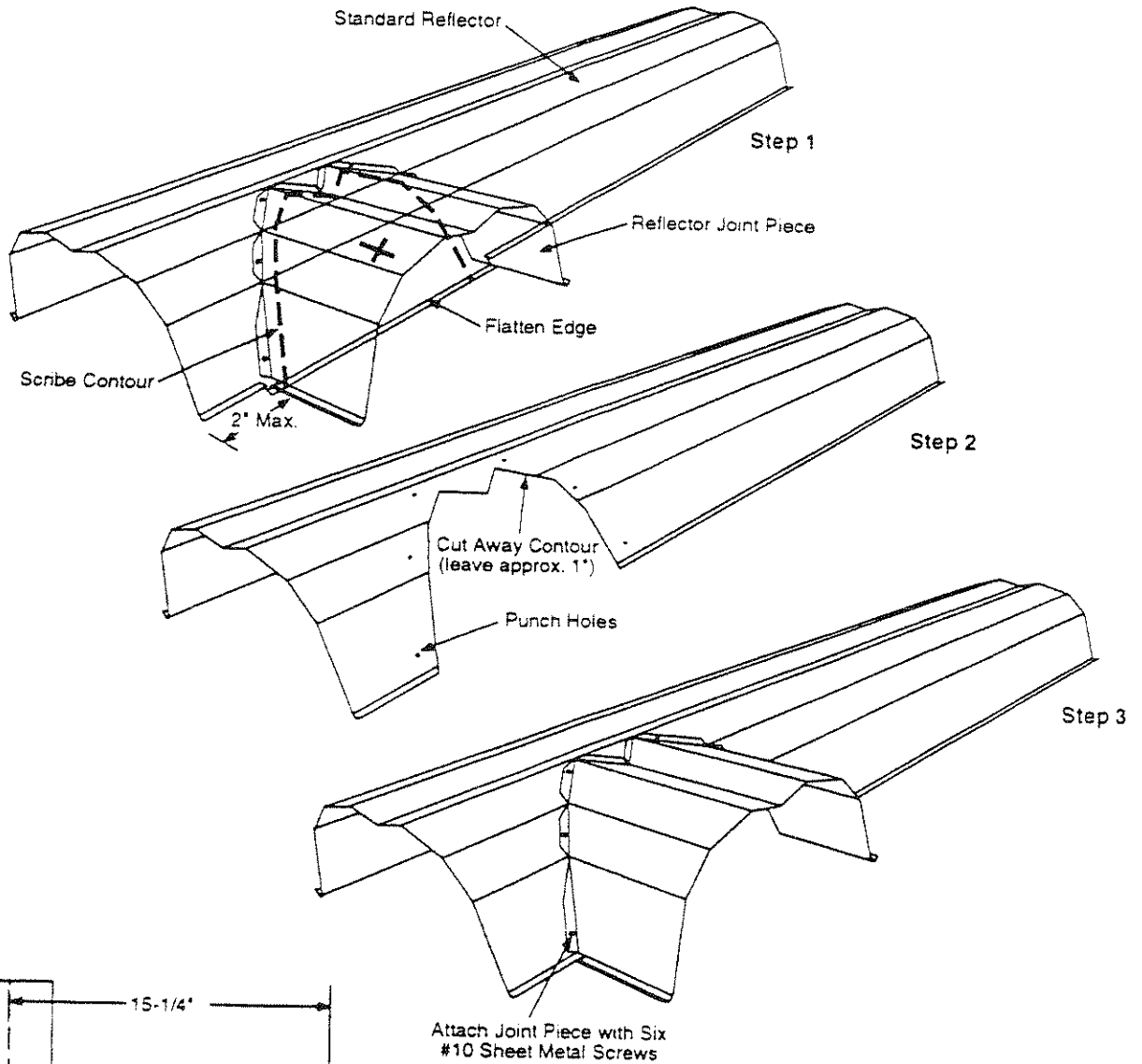

Elbow Fitting Dimensions

FIGURE 5: Typical Suspension Details

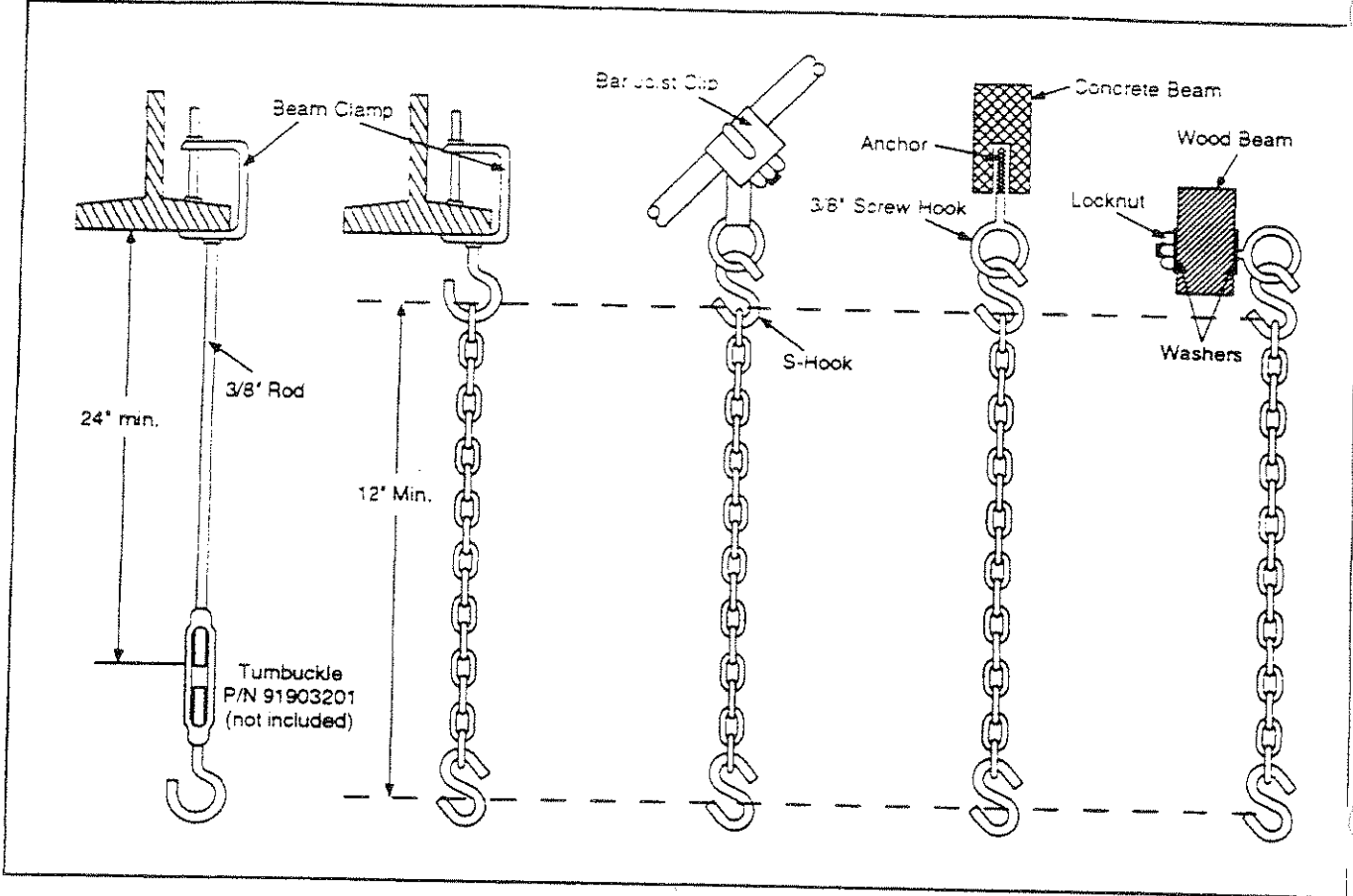

FIGURE 6: Tube Clamp Package Detail

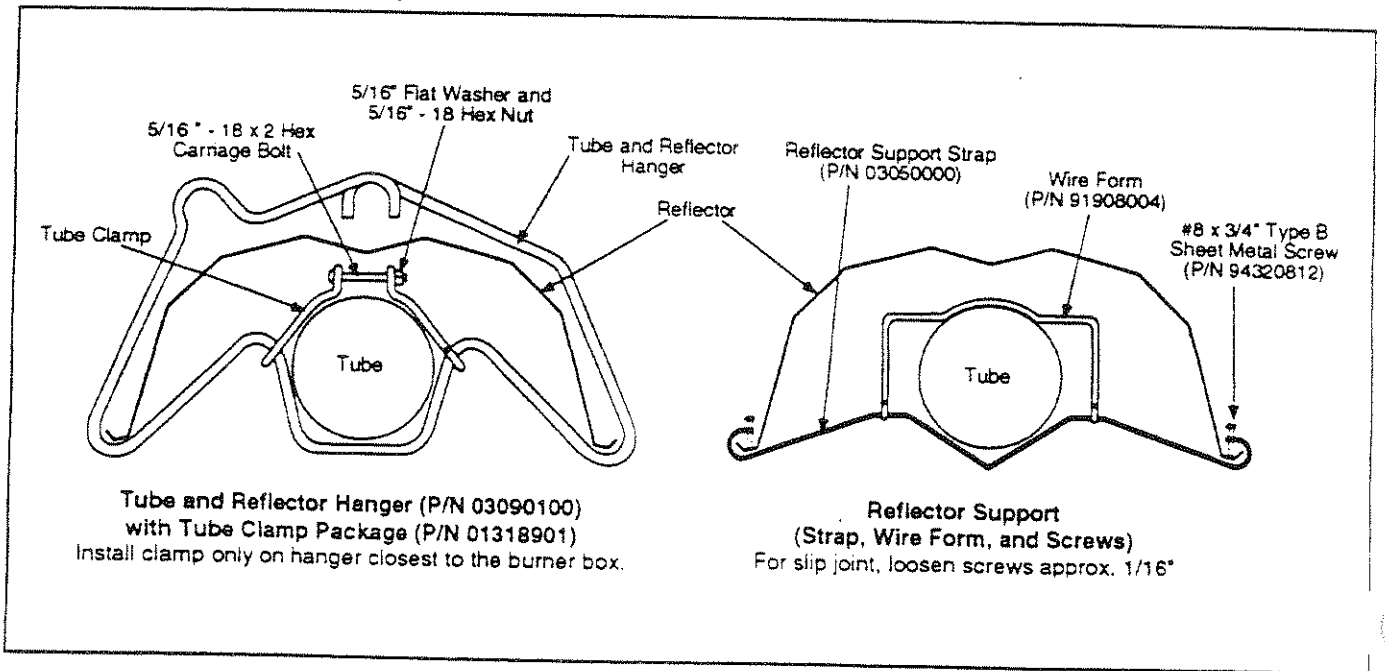

FIGURE 7: Turbulator Baffle Assembly Detail

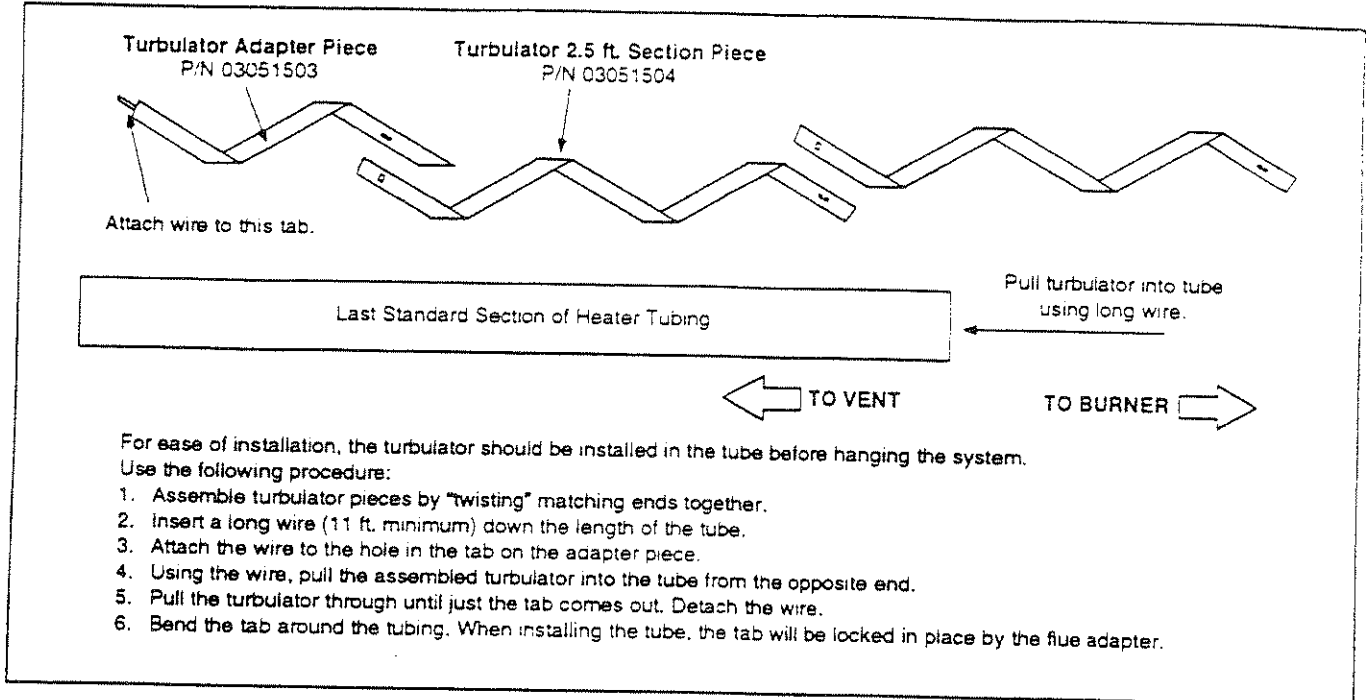
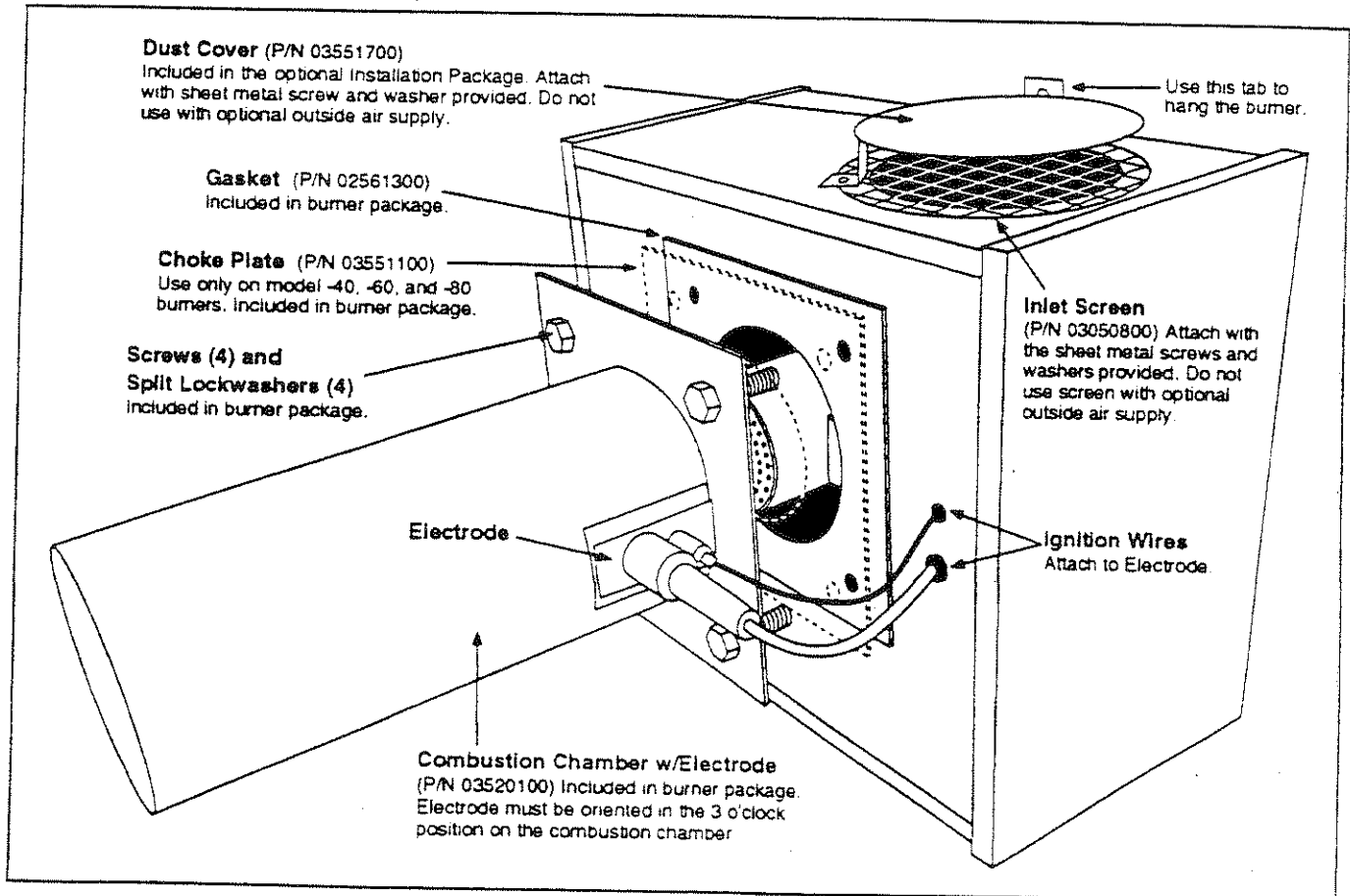

FIGURE 8: Burner Box Assembly



U-Tube Package

EconoRay heaters (except ER-40) are approved for optional U-Tube configurations. The U-Tube Package (P/N 03011000) includes: (1) 180° U-Tube, (1) Plain Coupling, (1) Tube and Reflector Hanger, (2) End Caps, (1) U-Tube Support Bracket and (2) 4" U-Bolts with Lockwashers and Hex Nuts.

Shown below is an example ER-125 U-Tube configuration. One of the 10 ft. tubes was cut in half to balance the sides. (The layout does not need to be symmetrical.) One (1) additional coupling was needed to complete the installation. The U-Tube may be installed in either a standard horizontal position or in an opposite 45° position as shown below. When designing a U-Tube configuration, the following rules must be adhered to:

- 1) A minimum of 10 ft. on ER-60/80/100 and a minimum of 15 ft. on ER-125/150/175/200 is required between the burner and the U-Tube.
- 2) The correct turbulator must be installed in the last standard section of heater tube.
- 3) The burner must never be operated in a tilted position.
- 4) The heater must be properly supported at all locations.

FIGURE 9: U-Tube Package Assembly Overview (optional)
 Use Figure 2 as a guide to the symbols used.

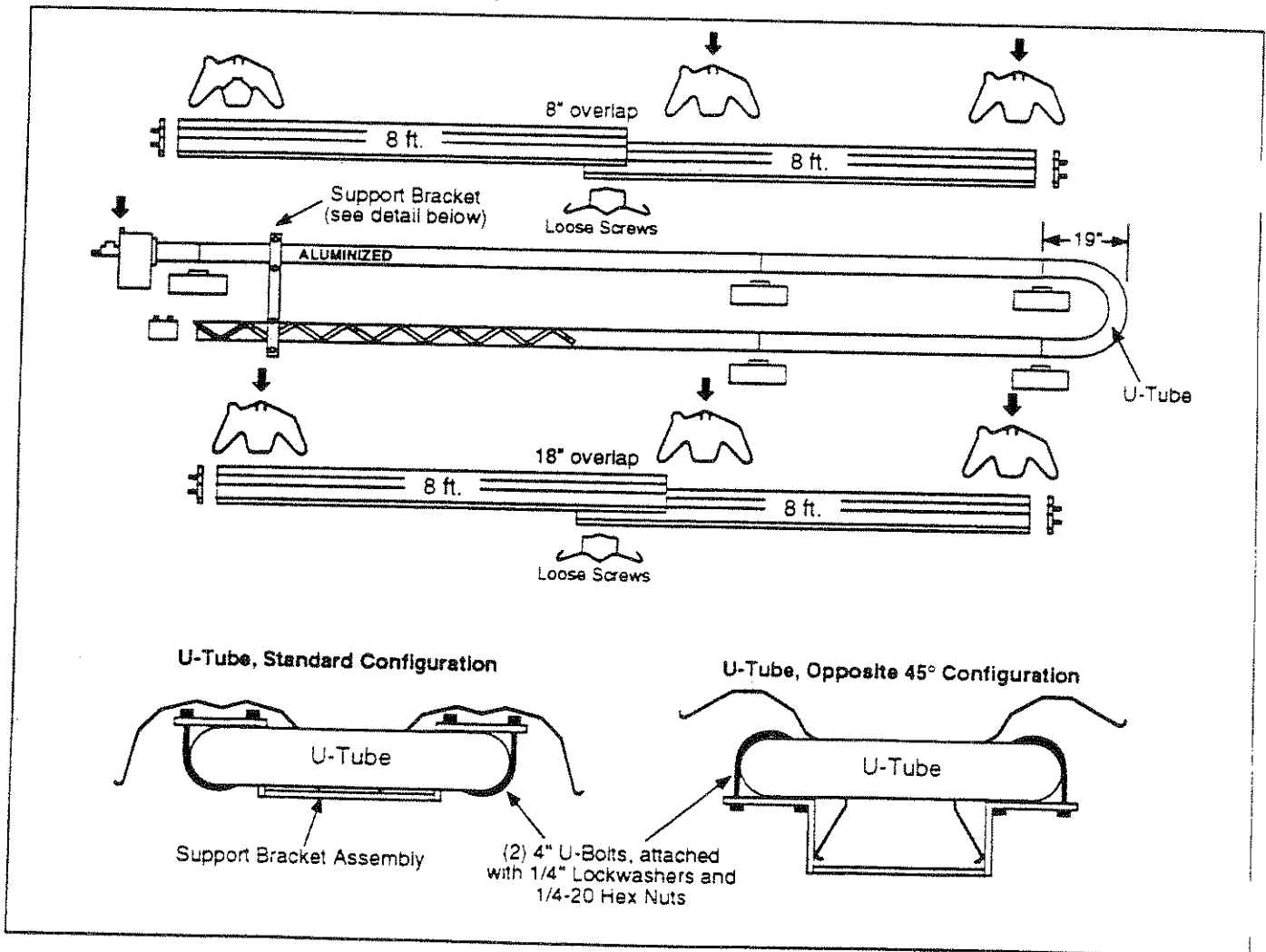

General Requirements

Heater must be vented in accordance with specification ANSI Z223.1 - latest revision. Partial information relating to this specification is provided in this section with regard to size and configurations for venting arrangements (see Figures 11,12,13,14,15). For complete information consult ANSI Z223.1 - latest revision and applicable local codes. Use the following guidelines to help insure an adequate, safe venting arrangement:

- a) Be sure that method selected for venting heater complies with all codes as required for each particular location.
- b) Exhaust end of heater will accept a four inch flue pipe using the flue pipe adapter (provided in the optional EconoRay Installation Kit).
- c) Heater may be vented to the outdoors either vertically or horizontally.
- d) If heater is to be vented horizontally:
 - 1) Vent must exit building not less than seven feet above grade when located adjacent to public walkways.
 - 2) Vent must terminate at least three feet above any forced air inlet located within ten feet.
 - 3) Vent must terminate at least four feet below, four feet horizontally from, or one foot above any door, window, or gravity inlet into any building.
 - 4) Vent terminal shall be located at least 12 inches from any opening through which vent gases could enter a building.
- e) Vent terminal opening must be beyond any combustible overhang.
- f) If condensation in the flue is a problem, the flue length should be shortened or insulated.
- g) For ER-40, -60, -80, -100 all of the following conditions must be met:
 - 1) Maximum total vent length allowed is 30 feet.
 - 2) Maximum outside air supply duct allowed is 20 feet.
 - 3) Maximum total vent length plus outside air supply length plus extension package shall not exceed 45 feet.
 - 4) Under length conditions 1) through 3) above, a total of 2 elbows are allowed for vent and outside air supply together. Subtract 15 feet per additional elbow from maximum length allowed if more than 2 elbows are used.
- h) For ER-125, -150, -160, -175, -200 all of the following conditions must be met:
 - 1) Maximum total vent length allowed is 40 feet.
 - 2) Maximum outside air supply duct allowed is 20 feet.
 - 3) Maximum total vent length plus outside air supply length plus extension package shall not exceed 50 feet.
 - 4) Under length conditions 1) through 3) above, a total of 2 elbows are allowed for vent or outside air supply together. Subtract 15 feet per additional elbow from maximum length allowed if more than 2 elbows are used.

Alternative Arrangements/Optional Equipment for Venting

- For unvented operation:**
- a) Sufficient ventilation must be provided in the amount of 4 cfm per 1000 BTU/hr firing rate.
 - b) Refer to ANSI Z223.1 - latest revision (NFPA No. 54) and local codes for additional information.
 - c) Use of optional outside combustion air is not recommended with unvented heaters due to pressure considerations.

- For horizontal venting:**
- a) In combustible or noncombustible walls use Tjernlund VH1-4" (P/N 90502100.) Follow vent manufacturer's instructions for proper installation. (Alternative vent Roberts-Gordon P/N 02537800, noncombustible wall only.)
 - b) 4" O.D. flue pipe is required, 30 feet maximum length is recommended. Up to 40 feet maximum may be used if insulated to prevent excess condensation. (See *General Requirements* on pg. 21 for additional information.)
 - c) All flue joints should be sealed using suitable product such as General Electric RTV106 or Permatex Form-a-Gasket Red High Temperature Silicone Adhesive Sealant.
 - d) Vent terminal should be installed at a height sufficient to prevent blockage by snow.
 - e) Building materials should be protected from degradation by flue gases.

- For vertical venting:**
- a) 4" O.D. flue pipe, maximum 40 feet in length may be used as shown with an approved vent cap. (See *General Requirements* on pg. 18 for additional information.)
 - b) An insulating thimble may be required to pass through combustible structures (check local codes).
 - c) All flue joints should be sealed using suitable products (see recommendation for horizontal venting).

- Venting with draft hood:**
- a) Refer to ANSI Z223.1 - latest revision (NFPA No. 54) for heights and vent sizes recommended for proper venting. (Check local codes for additional information).
 - b) Minimum six-inch O.D. vent is recommended.

- For common venting:**
- a) Horizontal run to vent must never exceed 75% of the vertical height of the vent. (Refer to ANSI Z223.1 - latest revision, (NFPA No. 54) for proper vent sizes and installation.)
 - b) Open area of common vent must equal the sum of the open area of individual flue vents connected to it (see chart on diagram).
 - c) Use double wall vent as required (check codes).
 - d) Heaters sharing a common vent must be controlled by the same thermostat.
 - e) All joints must be sealed using suitable products (see recommendation for horizontal venting).
 - f) Connection of common stack must be positioned to avoid direct opposition between sides of combustibles.

- Outside Air Supply:** Outside air supplies require the installation of an Outside Air Collar (P/N 91911700, included in the optional EconoRay Installation Package) on the EconoRay burner. See procedure and diagram on pg. 26.

Figure 11: Unvented Operation

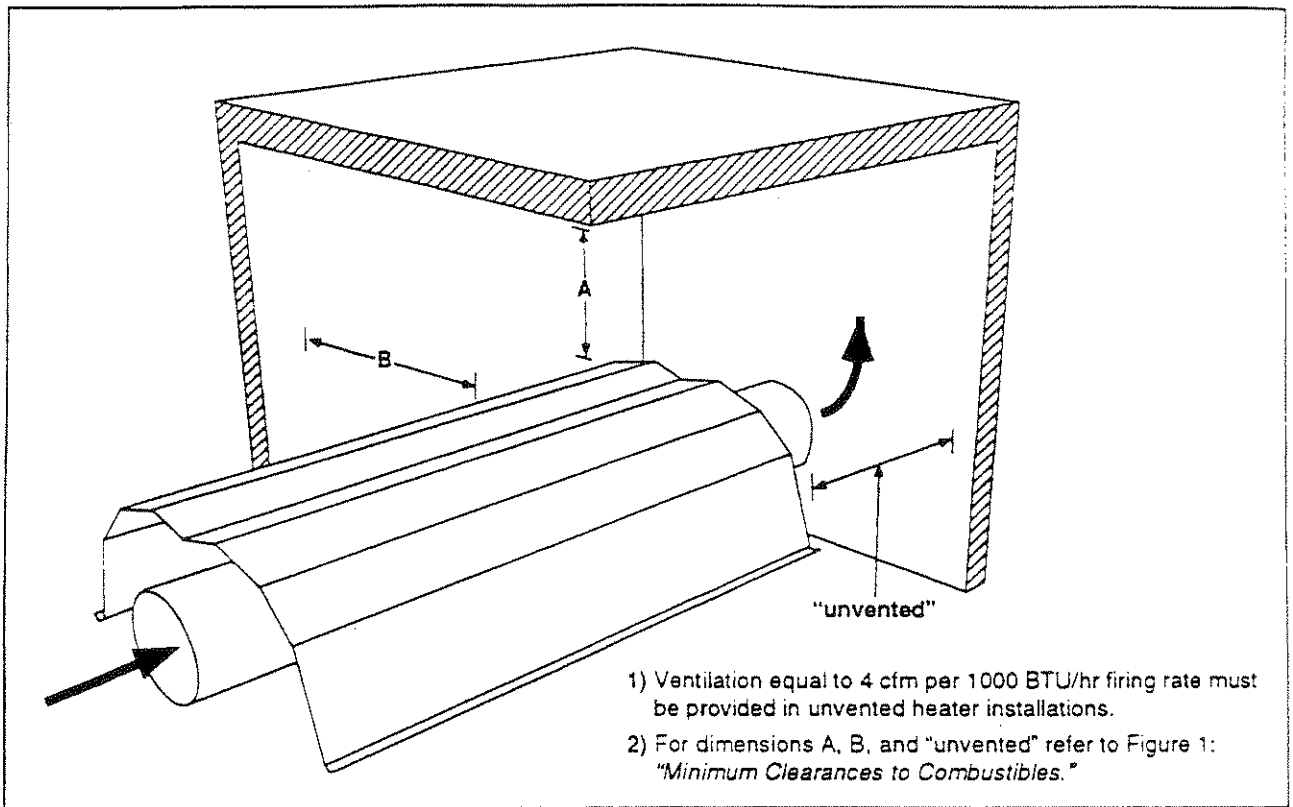

Figure 12: Horizontal Venting

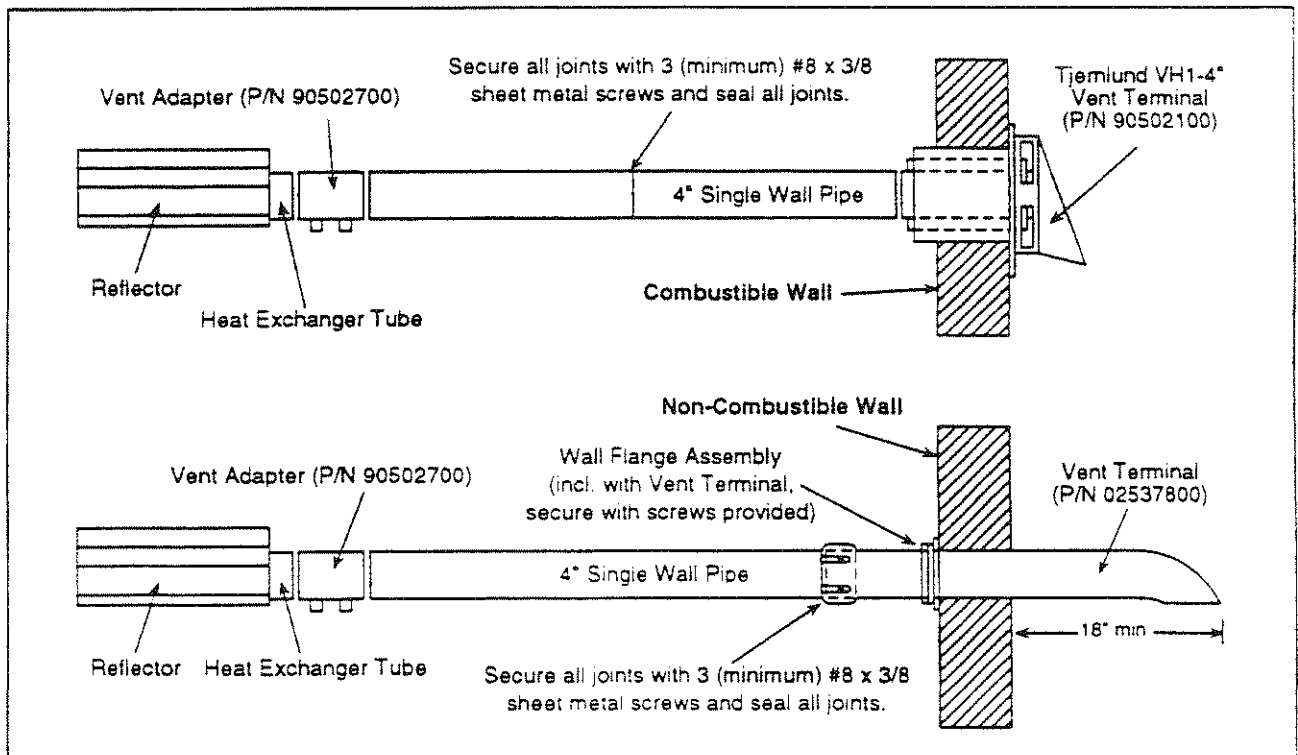

Figure 13: Vertical Venting

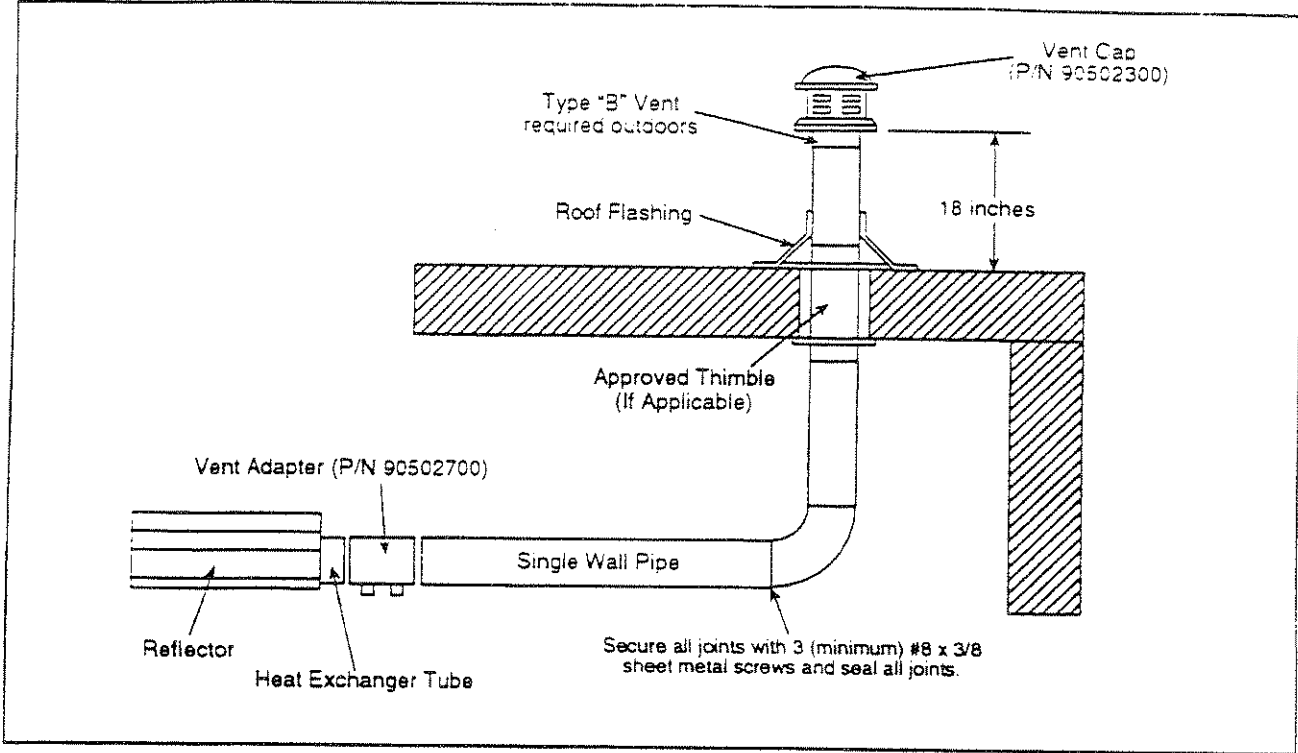

Figure 14: Vertical Venting with Draft Hood

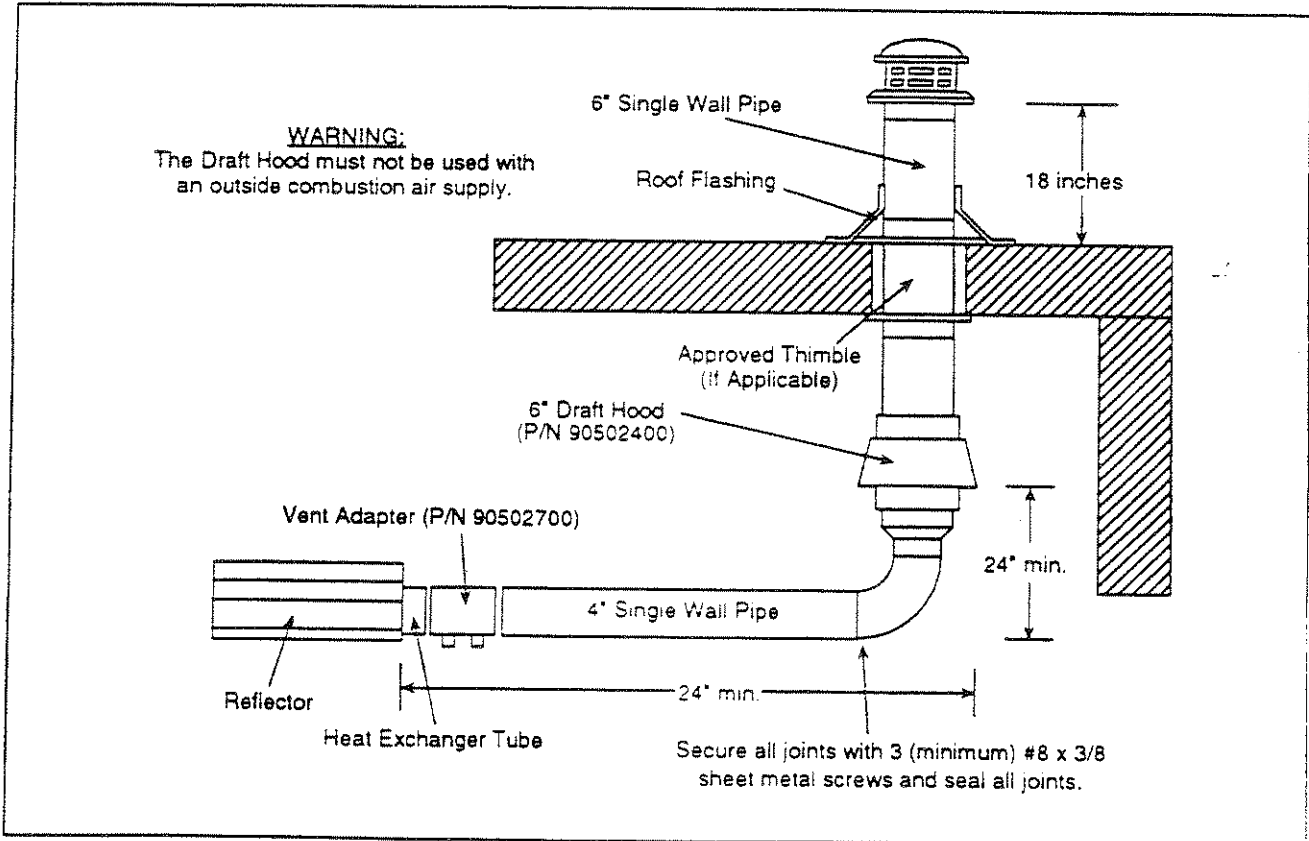
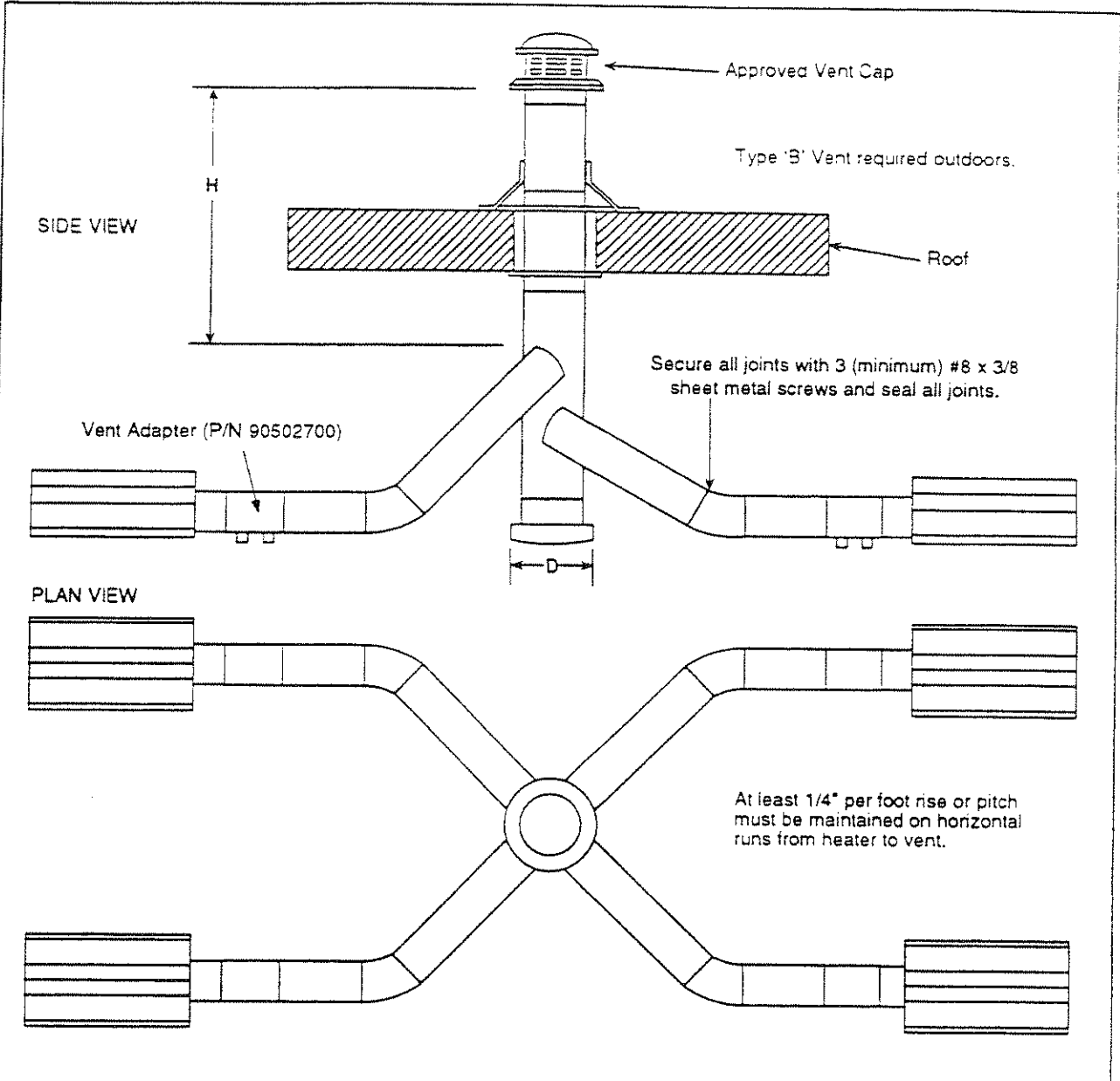

Figure 15: Common Roof Venting



COMMON VENTING - 2 HEATERS:

Model #	H = 6ft.	H = 8ft.	H = 15ft.
ER 40	D = 6"	D = 5"	D = 5"
ER 60	D = 7"	D = 6"	D = 6"
ER 80	D = 8"	D = 7"	D = 6"
ER 100	D = 8"	D = 8"	D = 7"
ER 125	D = 10"	D = 10"	D = 8"
ER 150	D = 10"	D = 10"	D = 8"
ER 175	N/A	N/A	N/A
ER 200	N/A	N/A	N/A

COMMON VENTING - 4 HEATERS:

Model #	H = 6ft.	H = 8ft.	H = 15ft.
ER 40	D = 8"	D = 7"	D = 6"
ER 60	D = 10"	D = 10"	D = 8"
ER 80	D = 10"	D = 10"	D = 10"
ER 100	N/A	D = 12"	D = 10"
ER 125	N/A	D = 12"	D = 10"
ER 150	N/A	N/A	D = 12"
ER 175	N/A	N/A	N/A
ER 200	N/A	N/A	N/A

Outside Combustion Air Supply

The EconoRay heater is approved for installation with an outside air supply system. Some compounds such as halogenated hydrocarbons or other corrosive chemicals in the air can be drawn into the equipment and cause an accelerated rate of corrosion of some of the heater components. The use of such chemical compounds near the enclosure should be avoided.

IMPORTANT: If the building has a slight negative pressure or contaminants are present in the air, an outside combustion air supply to the heaters is strongly recommended.

To use an outside air supply, the optional Outside Air Collar must be attached to the burner. See the illustration below for assembly instructions. For an outside air supply, a 4" O.D. single wall pipe may be attached to the heater. The duct may be up to 20 ft. maximum length or 2 ft. minimum length with no more than 2 elbows. See *General Requirements* heading on pg. 18 for more detailed guidelines. An outside air supply should not be used with the draft hood venting configuration.

The air supply duct may have to be insulated to prevent condensation on the outer surface. The outside air terminal should be securely fastened to the outside wall by drilling four 1/4" diameter holes in the outside flange; wood screws or bolts and expansion sleeves may be used to fasten the terminal.

Figure 16: Non-Pressurized Outside Air Supply Duct

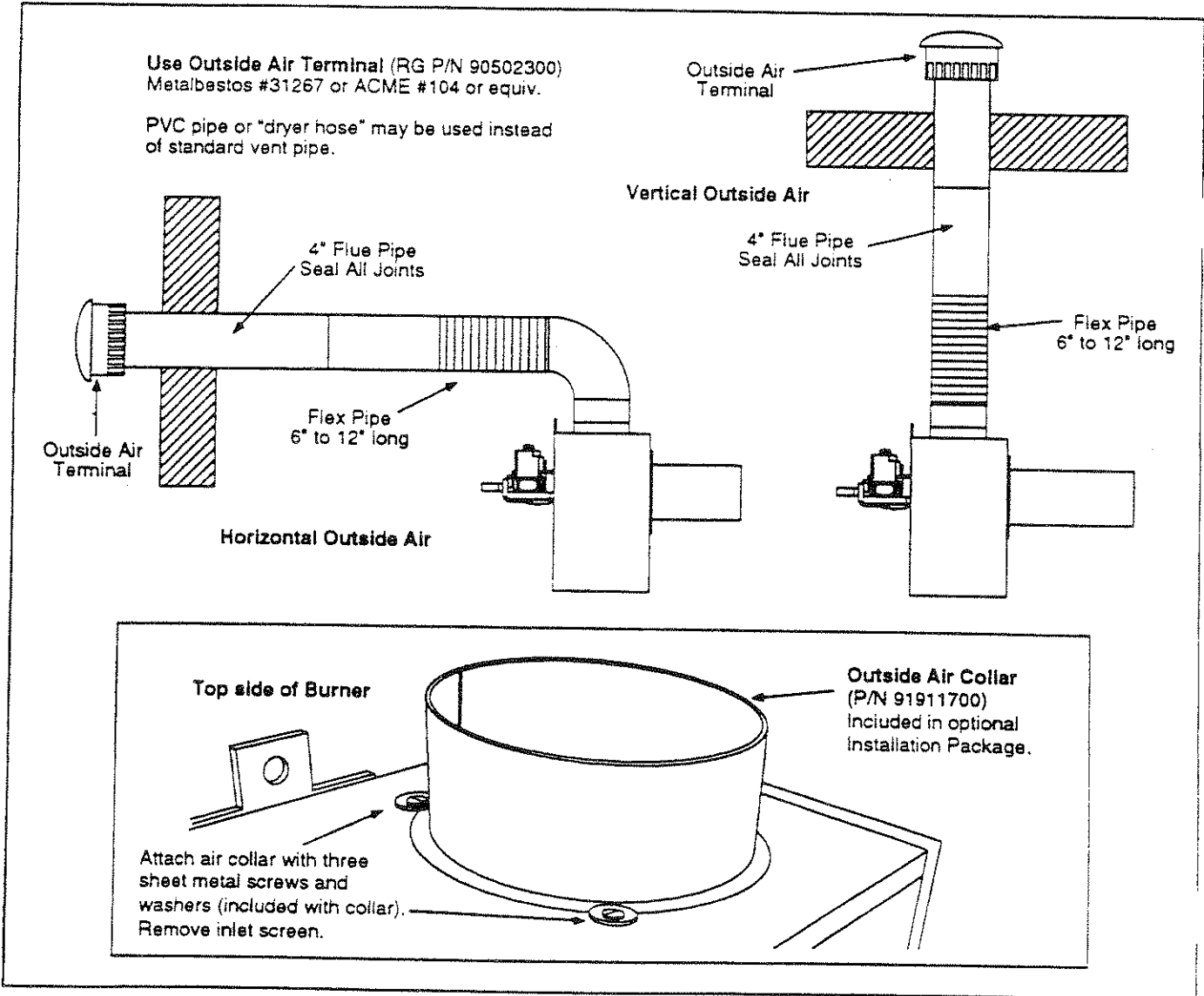

GAS PIPING

Section 6

Read applicable warnings in Section 1 before proceeding with Gas Piping installation. Improper installation may result in property damage, severe injury, or death.

Meter and service must be large enough to handle all the burners being installed plus any other connected load. The gas line which feeds the system must be large enough to supply the required gas with a maximum pressure drop of $\frac{1}{2}$ " water column. When gas piping is not included in the layout drawing, the local gas supplier will usually help in planning the gas piping.

A $\frac{1}{2}$ " tapping at each burner location must be located and oriented as shown in Figure 17. To check system pressure, put a plugged $\frac{1}{2}$ " NPT tapping in the gas line at the connection to the burner farthest from the supply. Before connecting the burners to the supply system, verify that all high pressure testing of the gas piping has been completed. **Do not high pressure test the gas piping with the burners connected.**

Follow these instructions to ensure a professional gas supply system installation:

- Support all gas piping with suitable pipe hanging materials.
- Use wrought iron or wrought steel pipe and malleable iron fittings. All pipe and fittings should be new and free from defects. Carefully ream the pipe and tubing ends to remove obstructions and burrs.
- Use L.P. gas-resistant joint compound on all pipe threads.
- Check the pipe and tubing ends for leaks before placing heating equipment into service. When checking for gas leaks, use a soap and water solution; **never use an open flame.**

Install the flex gas connector as shown. The flex gas connector accommodates expansion of the heating system and allows for easy installation and service of the burner.

FIGURE 17: Gas Line Connection with Stainless Steel Flex Gas Connector

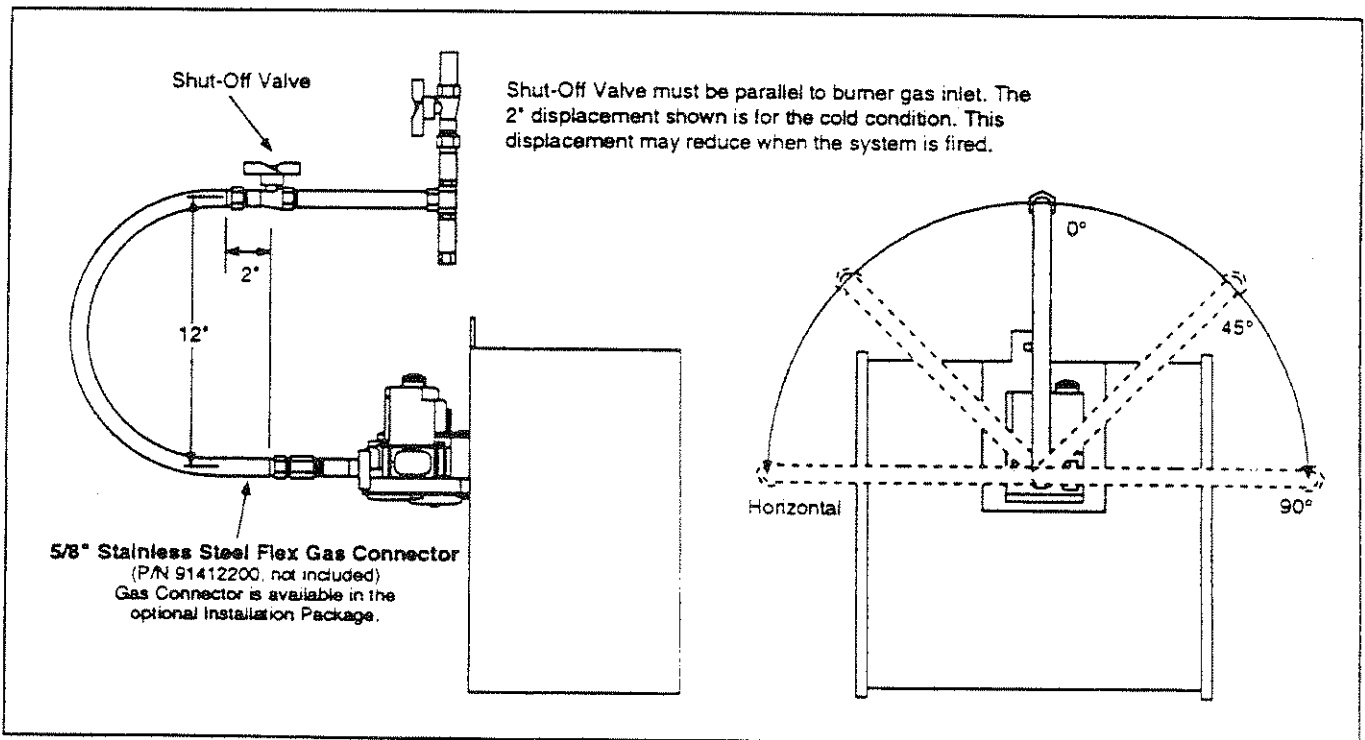

WIRING

Section 7

Heaters are normally controlled by thermostats. Line voltage thermostats are wired directly (see Figure 18); the recommended 24V thermostats use a relay (see Figure 19). Heaters must be grounded in accordance with National Electrical Code ANSI/NFPA 70 - latest revision. Heaters may also be controlled with a manual line voltage switch or timer switch in place of the thermostat.

FIGURE 18: Line Voltage Thermostat Wiring

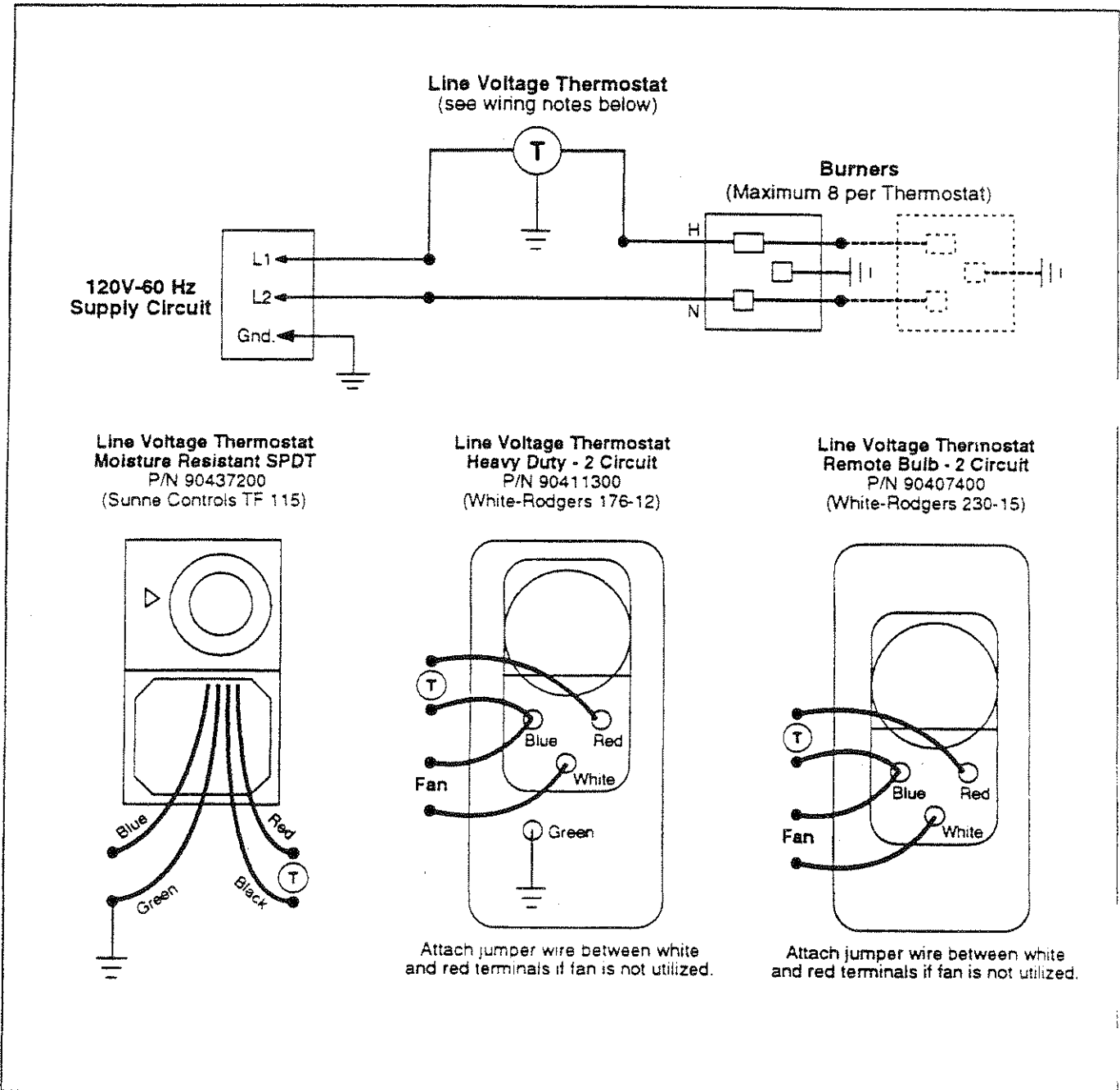

FIGURE 19: Wiring of Low Voltage Thermostat and Relay

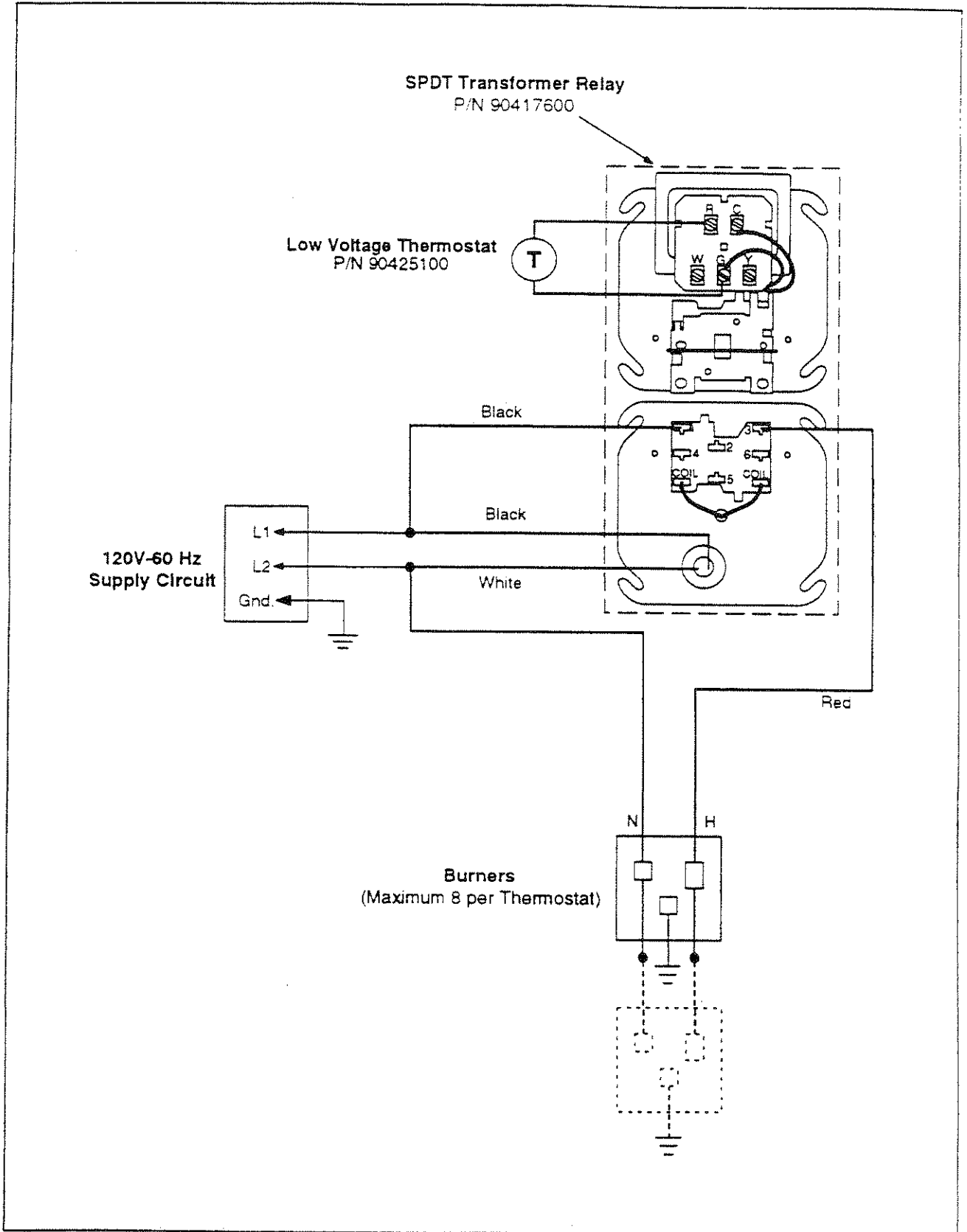
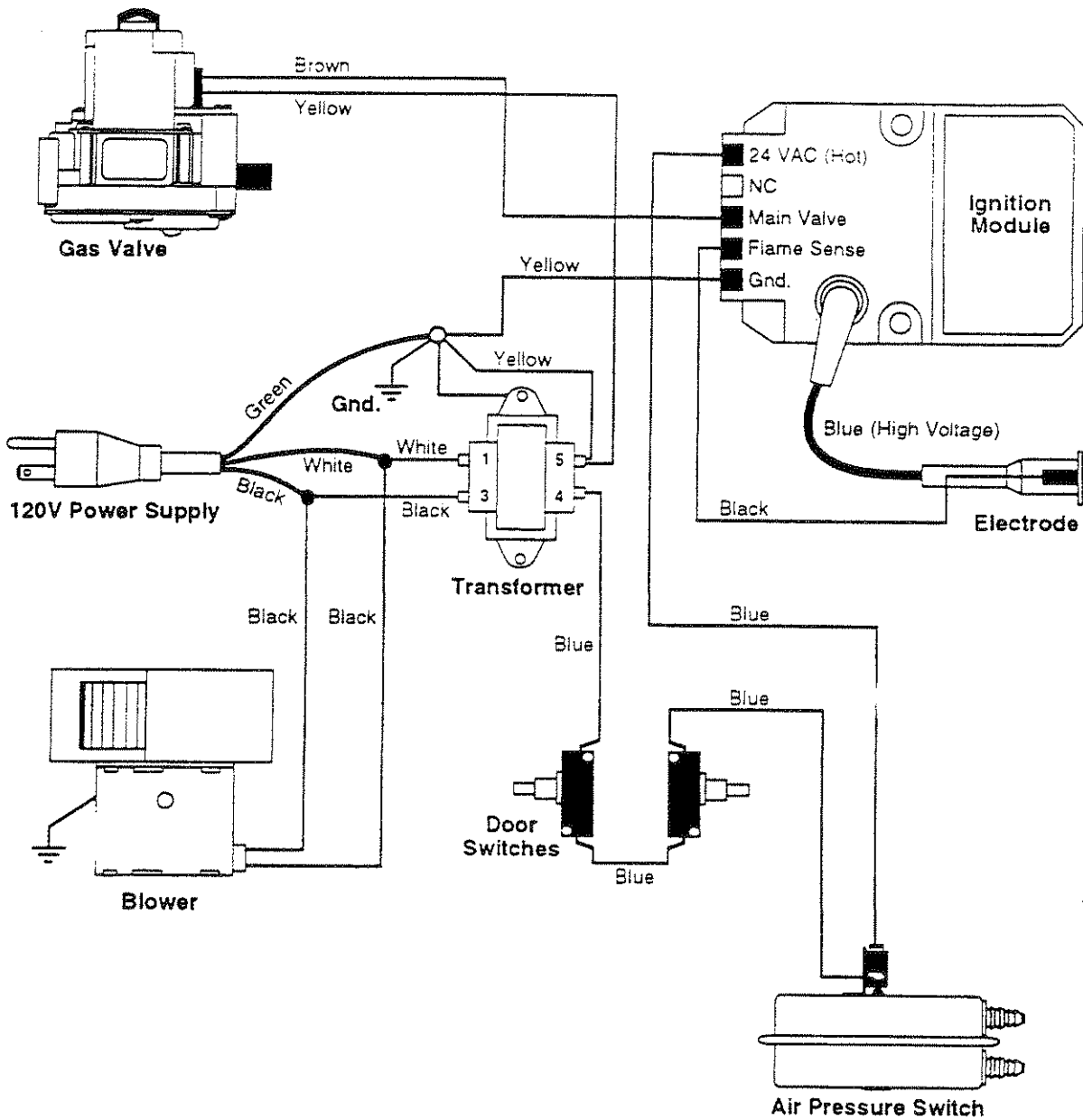
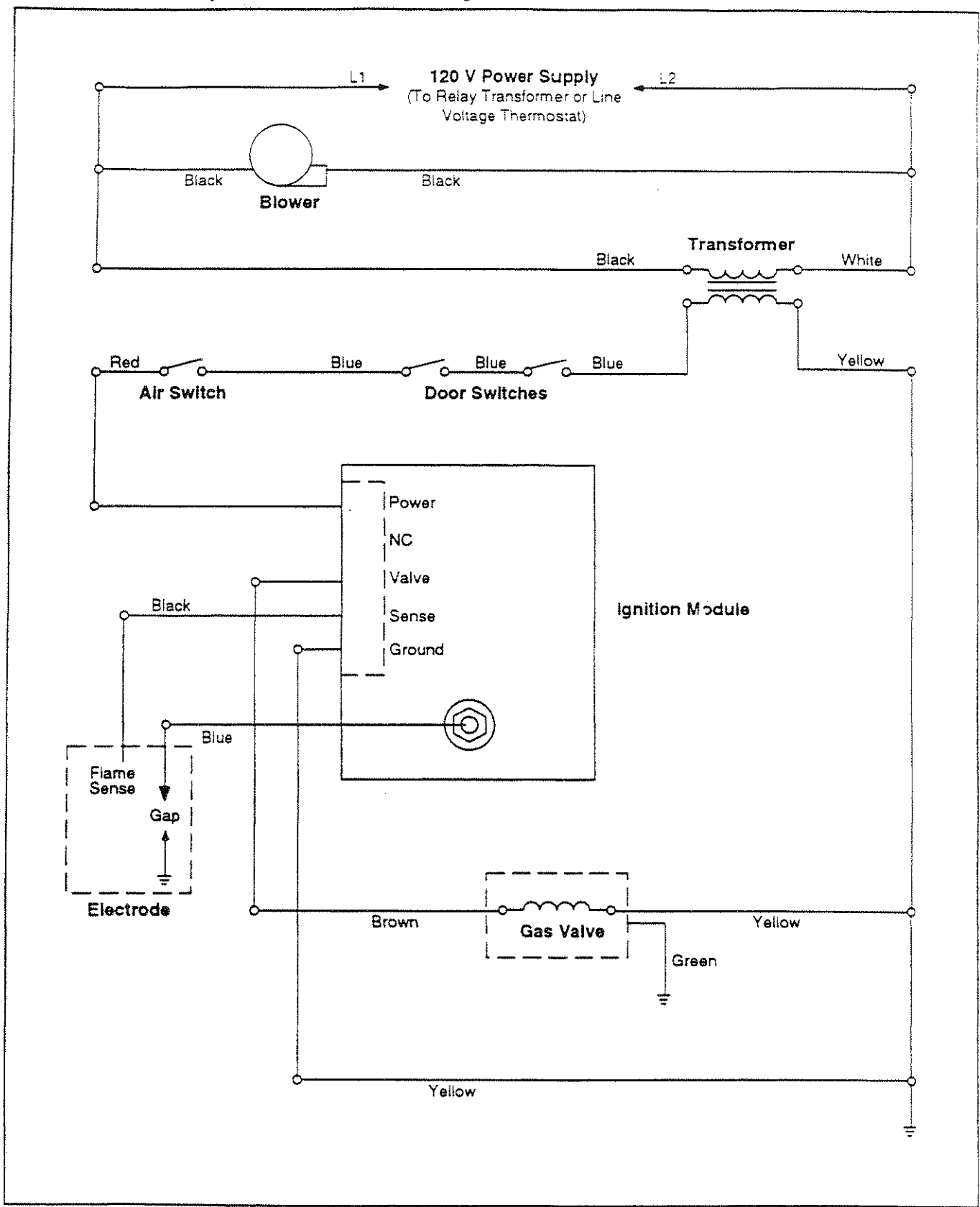

FIGURE 20: EconoRay Burner Internal Wiring



- If any of the original wire as supplied with the appliance must be replaced, it must be replaced with wiring material having a temperature rating of at least 105°C and 600 volts.
- Each burner must be electrically grounded in accordance with National Electrical Code ANSI/NFPA 70 (latest edition).

FIGURE 21: EconoRay Burner Internal Ladder Diagram



OPERATION AND MAINTENANCE**Section 8**

The EconoRay heater is equipped with a direct spark ignition system.

Sequence of Operation

1. Turn the thermostat up. When the thermostat calls for heat, the blower motor will energize.
2. When the motor approaches nominal running RPM, the air proving switch closes and activates the ignition module.
3. The ignition module then opens the redundant gas valve and energizes the spark igniter.
4. When the flame is established, the sparking sequence ceases.
5. If the flame is not established during the ignition sequence, the ignition module closes the gas valve and purge begins. Module will try 2 additional times for ignition (with purge in between). If ignition is not established, the module will lock out.
6. If the flame extinguishes during operation, the ignition module will provide multiple trial sequence described in step 5. If ignition is not re-established, the module will lock out.
7. After lockout, control must be reset by turning down thermostat for five (5) seconds, and then raising it again to desired temperature, or unplugging cord, and then plugging it in again.
8. When thermostat is satisfied, all power to the unit is shut off.

Maintenance

For best performance, the following maintenance procedures should be performed before each heating season:

1. **Be sure gas and electrical supply to heater are off before performing any service or maintenance.**
2. Check condition of blower scroll and motor. Dirt and dust may be blown out with compressed air, or a vacuum cleaner may be used.
3. Check condition of burner. Carefully remove any dust or debris from inside the burner box or mixing tube.
4. Inspect the electrode. Replace electrode if there is excessive carbon residue, erosion of electrodes or other defects. Gap should be 0.125".
5. Check the inside of the firing tube with a flashlight. If carbon or scale are present, scrape out the deposits with a wire brush or rod, or metal plate attached to a wooden pole.
6. Check the flue pipe for soot or dirt. After cleaning as necessary, re-attach the flue pipe to the heater.
7. Outside surfaces of heater reflector may be cleaned by wiping with a damp cloth.
8. A qualified service agency should be contacted for service other than routine maintenance.
9. Check vent terminal and fresh air inlet to see that they have not become blocked during the non-heating season. If either pipe is restricted, the air switch won't close, resulting in a no-heat situation.

Troubleshooting

CAUTION: Before opening the EconoRay burner doors for any type of service, be sure the gas supply has been shut off at the heater, and the electrical cord from the burner box has been unplugged.

No Power (Heater plugged in)

1. Check to see that the thermostat is calling for heat.
2. Check fusing in electrical supply to heater.
3. Check for 120V at receptacle.

Blower Motor Fails to Run

1. Check for broken motor wire
2. Does blower wheel turn freely? Replace the motor if it is seized.

No Spark

1. Turn off gas and check for spark at the burner.
2. Some ignition modules have a built-in pre-purge. Wait 45 seconds and try again.
3. Recycle thermostat or power if no spark appears.
4. Check for loose or broken leads.
5. Replace door switch if faulty.
6. Replace air switch if faulty.
7. Check electrode gap. Gap should be 0.125"
8. Make sure that the total length of outside air vent and flue pipe has not been exceeded.
9. Check the vent and vent terminal for obstructions.
10. Check the plastic tubing connecting the air switch. A hole in the line will prevent ignition.

No Gas Present

Gas pressure downstream of gas control can be measured by using a manometer and connecting to pressure tap on control.

1. Check to see if manual valve to heater is ON.
2. Check to see if manual valve knob on heater gas control is ON.
3. Supply gas pressure can be checked at 1/8" NPT pressure tapping on heater external manual valve.
4. Check to see if gas control is opening: no manifold pressure indicates valve is closed.

If the valve is closed, either the gas valve or the ignition module is faulty.

WARNING: Do not disconnect ground leads inside heater. Do not interchange grounded and ungrounded leads on transformer or ignition module.

Burner Lights and Then Goes Out

Flame current is the current which passes through the flame from the sensor to ground to complete the primary circuit. A minimum flame generated current, usually about 2.0 μ A is necessary to prevent lockout.

To measure flame current, disconnect the black sensor wire at the electrode and insert a 0-50 μ A DC meter in the circuit. **TURN OFF ELECTRICAL POWER BEFORE INSERTING METER INTO CIRCUIT.**

If insufficient flame current is present, inspect electrode and check electrical grounds. Repair as necessary.

FIGURE 22: EconoRay Troubleshooting Flow Chart

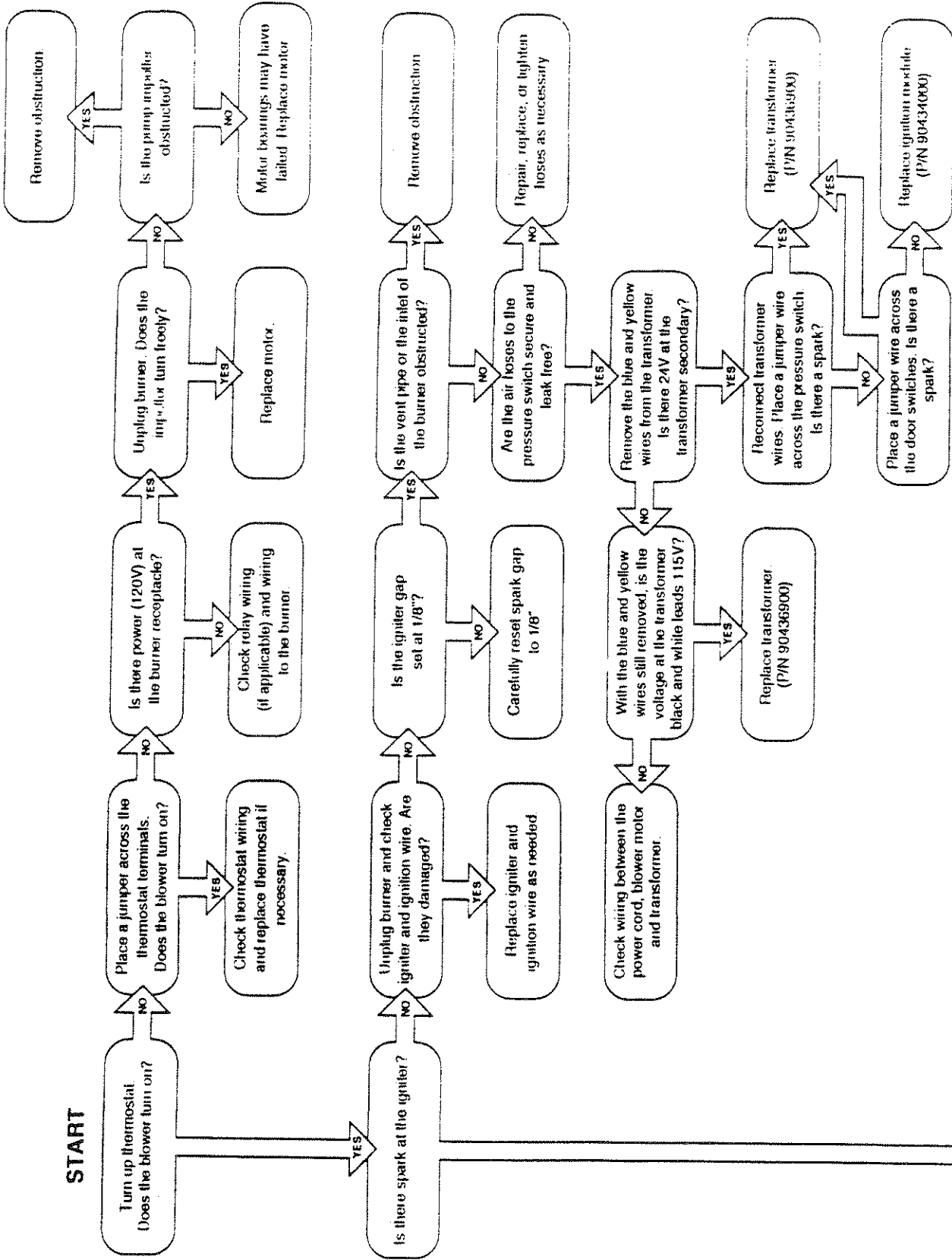

APPENDIX III: General Specifications Section 9

General specifications for EconoRay ER-Series heaters are as follows:

Burner Ratings and Heat Exchanger Lengths: (Natural and LP)

Model	Rate (Btu/hr)	Natural Fuel			LP Fuel		
		Min. Length	Max. Length	Turbulator	Min. Length	Max. Length	Turbulator
ER-40	40,000	10 ft.	20 ft.	7 ft.	20 ft.	20 ft.	none
ER-60	60,000	20 ft.	30 ft.	7 ft.	30 ft.	30 ft.	none
ER-80	80,000	20 ft.	30 ft.	7 ft.	30 ft.	30 ft.	none
ER-100	100,000	20 ft.	30 ft.	12 ft.	30 ft.	30 ft.	7 ft.
ER-125	125,000	30 ft.	50 ft.	10 ft.	40 ft.	50 ft.	none
ER-150	150,000	40 ft.	60 ft.	5 ft.	50 ft.	60 ft.	none
ER-175	175,000	50 ft.	70 ft.	none	50 ft.	70 ft.	none
ER-200	200,000	60 ft.	80 ft.	none	60 ft.	80 ft.	none

Gas Pressure at Manifold:

Natural Gas: 3.5" W.C.
 LP Gas: 10.5" W.C.
 1/2" NPT Gas Connector Size

Gas Inlet Pressure:

Natural Gas: 4.6" W.C. Minimum 11.0" Maximum
 (5.0" Minimum for ER-200)
 LP Gas: 11.0" W.C. Minimum 14.0" Maximum

Dimensions:

Flue Connection Size: 4"
 Outside Air Connection Size: 4"
 Refer to figure below for dimensional information.

Electrical Rating: (All Models)

120V- 60 Hz., 1.0 Amp

FIGURE 23: EconoRay Dimensions and Suggested Mounting Heights

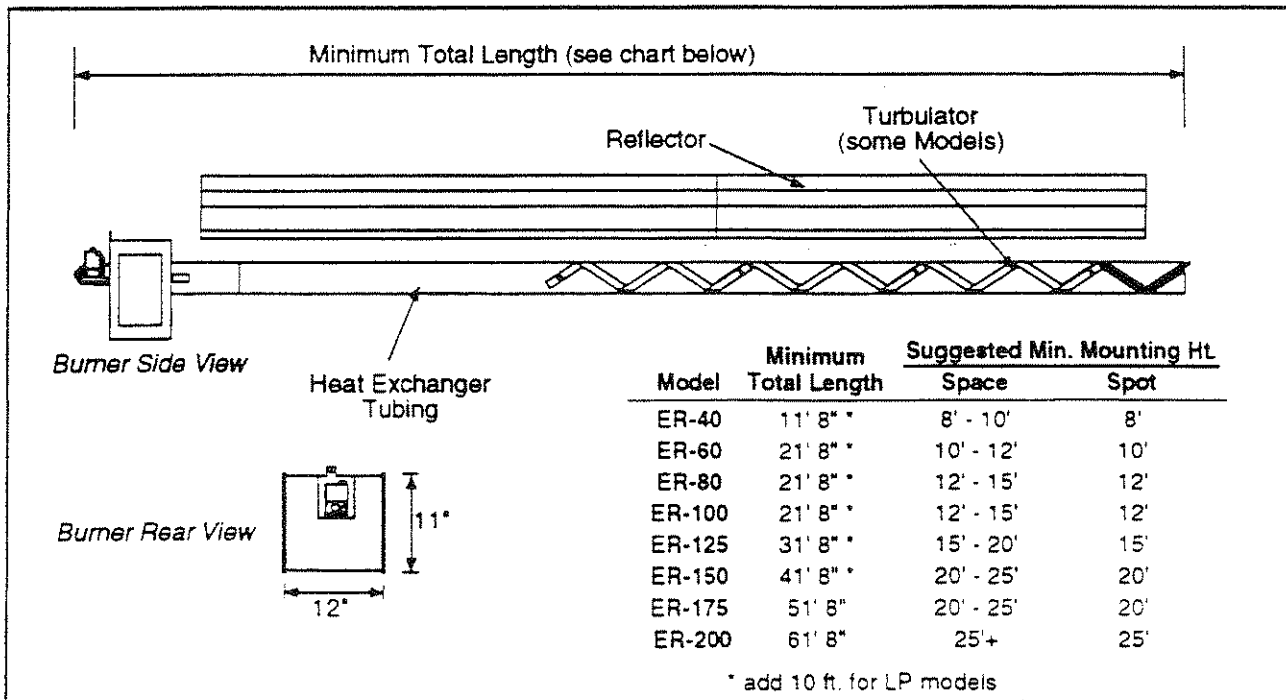

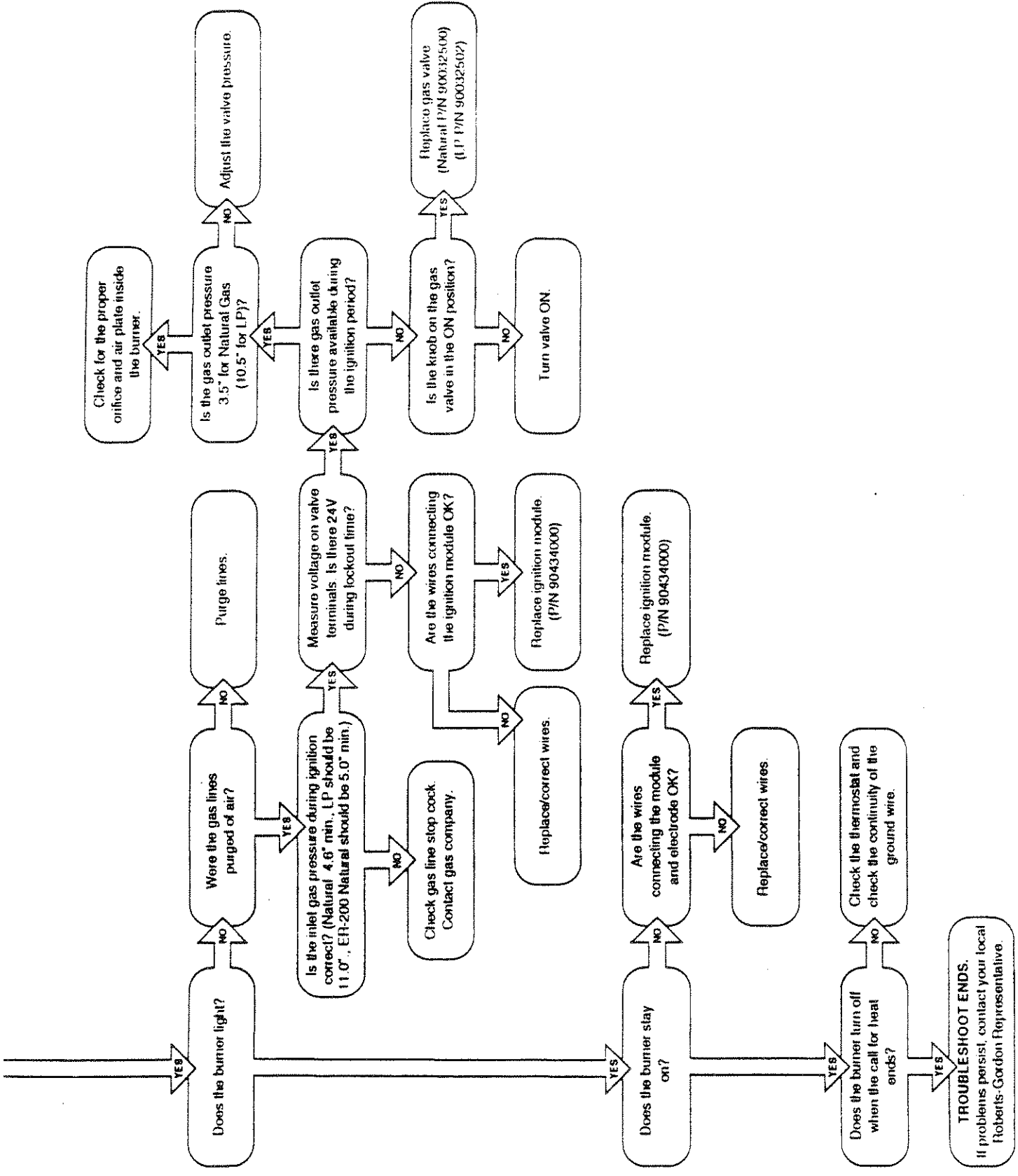

APPENDIX I: Replacement Parts**Section 9**TABLE 4: *EconoRay Replacement Parts*

Part Number	Description
90427402	Electrode
90436900	Transformer
90436700	Air Proving Switch (Models ER-150, ER-175, ER-200)
90436703	Air Proving Switch (Models ER-80, ER-100, ER-125)
90436704	Air Proving Switch (Models ER-40, ER-60)
90434000	Ignition Module
90604800	Motor
91911700	Outside Air Adapter
03510401	Burner Cup Assembly (LP Models ER-40, ER-60, ER-80)
03510402	Burner Cup Assembly (Natural Models ER-40, ER-60, ER-80)
03510403	Burner Cup Assembly (Natural Models ER-100, ER-125)
03510406	Burner Cup Assembly (Natural Models ER-150, ER-175, ER-200)
03510405	Burner Cup Assembly (LP Models ER-100, ER-125, ER-150, ER-175, ER-200)
90032500	Gas Valve - Natural
90032502	Gas Valve - LP
91318600	Viewer Window
90106400	Electrical Cord
90427700	Ignition Cable
03520000	Wire Harness
03550700	Combustion Chamber
02568200	Gasket, Burner to Transition Tube
03510300	Burner Door

APPENDIX II: Engineering Specifications**Section 9**

The total heating system supplied shall be design certified by the American Gas Association.

A. Burner and Burner Controls

1. Burners shall be capable of firing with one of the fuel options as specified on the purchase documents: Natural Gas or LP.
2. Burners shall be supplied to fire at any one of the input firing rates as specified:

ER-40	40,000 BTU/Hr.	ER-125	125,000 BTU/Hr.
ER-60	60,000 BTU/Hr.	ER-150	150,000 BTU/Hr.
ER-80	80,000 BTU/Hr.	ER-175	175,000 BTU/Hr.
ER-100	100,000 BTU/Hr.	ER-200	200,000 BTU/Hr.
3. Burner shall be equipped with fully automatic D.S.I. 100% shut-off ignition device. Power supplied to each heater shall be 120V, 60 HZ, single phase. Burners shall be rated for 1.0 Amps.
4. Burner shall be equipped with thermal overload motor protection, balanced air rotor, combustion air proving safety pressure switch, and viewing window for flame observation.
5. When specified, in contaminated environments, the burner shall be capable of supplying outside air to each burner for the support of combustion.
6. All burners shall be pre-wired with a grounded electrical cord and plug.
7. At customer's choice, burners may be controlled with either an optional line voltage thermostat or by optional low voltage thermostats with an appropriate low voltage transformer relay.
8. Gas supply to the burners shall conform to the following:
 - 1/2" NPT gas connector size
 - Natural Gas:** 4.6" W.C. MIN, 14.0" W.C. MAX
(5.0" W.C. MIN, 14.0" W.C. MAX for ER-200)
 - LP Gas:** 11" W.C. MIN, 14.0" W.C. MAX

B. Heat Exchanger

1. Radiant tubing shall be 4" diameter hot-rolled steel supplied in 10 ft. sections. Sections shall be joined stainless steel wrap-around couplings.
2. Reflector to be of aluminum material and designed to direct all radiant output below horizontal centerline of radiant tube.
3. Reflectors shall have end caps to prevent heat loss due to convection.
4. Heaters shall be vented according to manufacturer's recommendations.

EconoRAY LIMITED WARRANTY

Warranty Coverage:

ROBERTS-GORDON, INC. ("Seller") warrants that entire heating systems sold by it (individually a "System") and any replacement parts which it sells relating to any System ("Parts") shall be free from defects in workmanship and material for the time periods described as follows. With respect to a System this warranty shall apply for a period of three years from delivery to the original purchaser ("Buyer"). With respect to Parts, this warranty shall apply for the longer of the original System warranty period or for a period of one year. ("Systems" and "Parts" are hereinafter collectively referred to as "Products".) This warranty extends only to the original purchaser of Products.

Seller manufactures products which are designed only to provide predetermined ranges of heat rises in various enclosures when properly used in systems designed by purchaser or others and installed by others. Seller makes no representation or warranty with respect to the effect upon enclosure, or upon any of the contents of the enclosure, including, without limitation, all plant or animal life, kept or processed in the enclosure subject to the limitations outlined below.

Warning:

THIS WARRANTY IS VOID IF THE PRODUCTS HAVE BEEN DAMAGED DUE TO ACCIDENT, ABUSE, MISHANDLING OR ANY OTHER CAUSE WHATSOEVER OTHER THAN DEFECTS IN MATERIAL OR WORKMANSHIP. Specifically, Seller's warranty shall not apply: (a) to damage to Products when used in an atmosphere containing halogenated hydrocarbons or other corrosive chemicals. Some compounds in the air can be ingested into the equipment and can cause an accelerated rate of corrosion of some of the Products. The use of such chemical compounds in or near the enclosure should be avoided where a longer life of the burner, tubing and other parts is desirable; (b) to Products which have been repaired or replaced with other than factory parts, modified in any way, misused or damaged, or which have been installed or used contrary to Seller's written instructions or manuals; or (c) to any damage resulting from improper service or a lack of proper maintenance.

Limitations of Warranty:

OTHER THAN AS STATED HEREIN OR IN ANY OTHER WARRANTY OF SELLER, THERE ARE NO OTHER WARRANTIES OF ANY KIND WHATSOEVER, EXPRESS OR IMPLIED, AND ALL OTHER EXPRESS AND ALL IMPLIED WARRANTIES OF MERCHANTABILITY AND/OR FITNESS FOR ANY PARTICULAR PURPOSE ARE HEREBY SPECIFICALLY DISCLAIMED.

Exclusive Remedy:

THE SOLE AND EXCLUSIVE REMEDY FOR ANY LOSS, DAMAGE OR LIABILITY, OR OTHERWISE, IS LIMITED TO THE OBLIGATION OF SELLER TO REPAIR OR REPLACE PARTS, AT ITS FACTORY, OF ANY PRODUCT OWNED BY ORIGINAL BUYER AND RETURNED TO THE SELLER'S FACTORY WITHIN ONE YEAR AFTER INVOICE, WITH TRANSPORTATION CHARGES PREPAID, WHICH EXAMINATION REVEALS TO HAVE BEEN DEFECTIVE. UNDER NO CIRCUMSTANCES SHALL SELLER BE LIABLE FOR ANY LOSS, DAMAGE, COST, EXPENSES, OR INCIDENTAL OR CONSEQUENTIAL DAMAGES OF ANY KIND, IN CONNECTION WITH THE SALE, INSTALLATION, USE, MAINTENANCE, OR REPAIR OF ANY PRODUCT.

Buyer Responsible for Data:

Seller and its representative may furnish Buyer upon Buyer's request, data relating to the function and use of Products. Seller shall not be liable for loss, damage, cost, expenses or incidental or consequential damages of any kind, sustained directly or indirectly, by any person, or to any property, if Buyer adopts and uses such data in whole or in part.

Limitations on Authority of Representatives:

No representative of Seller, other than an Executive Officer, has authority to change or extend these provisions. Changes or extension shall be binding only if confirmed in writing by Seller's duly authorized Executive Officer.

Direct any question or warranty claims to the original installer:

Company: _____

Address: _____

Phone: _____

Or to: Warranty Claims, Roberts-Gordon, Inc.,
P.O. Box 44,
Buffalo, NY 14240-0044



1

2

3



4

5

6

7

