

HDCL REPLACEMENT PARTS DIAGRAM

BY; ENERGY SALES, INC

NOTE: This document is a parts replacement parts guide for replacing Heavy duty couplings in infrared heating systems by Roberts Gordon. for installation refer to the manual provided with IR system. For questions call us at 952-890-2966

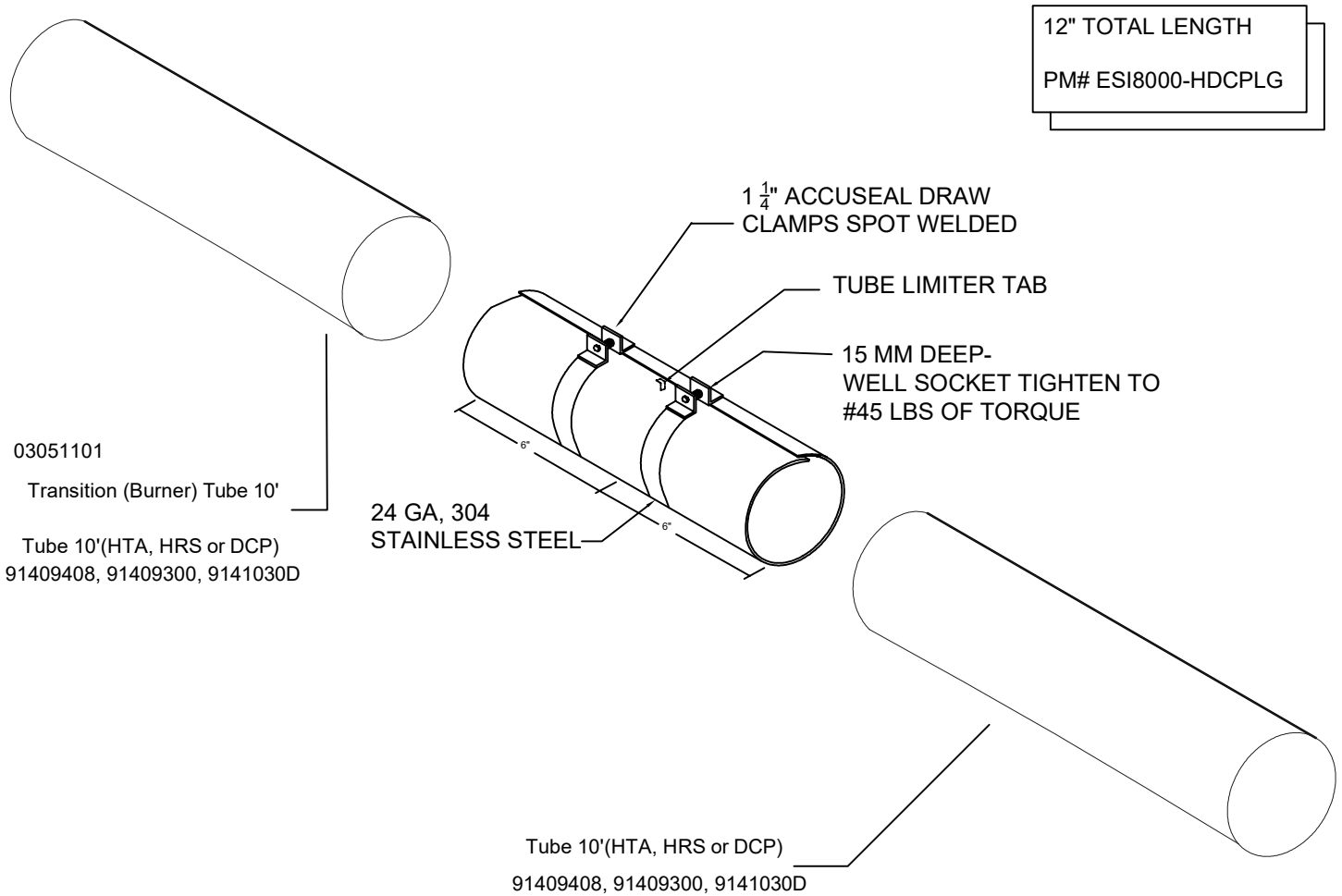

*Not to Scale